

# TM 11-5855-209-10

DEPARTMENT OF THE ARMY TECHNICAL MANUAL

---

OPERATOR'S MANUAL

NIGHT VISION SIGHT,  
MINIATURIZED  
AN/PVS-3

This copy is a reprint which includes current  
pages from Changes 1 THROUGH 5 .

---

HEADQUARTERS, DEPARTMENT OF THE ARMY  
28 DECEMBER 1967

## WARNING

The image intensifier tube phosphor screens contain toxic materials. If a tube becomes broken, avoid inhalation of the phosphor screen material and do not allow it to come in contact with the mouth or open skin wounds.

**Changes in force: C 1, C 2, C 3, C 4 and C 5**

TM 11-5855-209-10  
C5

**CHANGE**

No. 5

HEADQUARTERS  
DEPARTMENT OF THE ARMY  
WASHINGTON, DC, 6 September 1977

Operator's Manual  
NIGHT VISION SIGHTS  
AN/PV-3 (NSN 5855-00-832-9341) and  
AN/PVS (NSN 5855-00-156-4992)

TM 11-5855-209-10, 28 December 1967, is changed as follows:

Title is changed as shown above.

Add Radiation Warning.

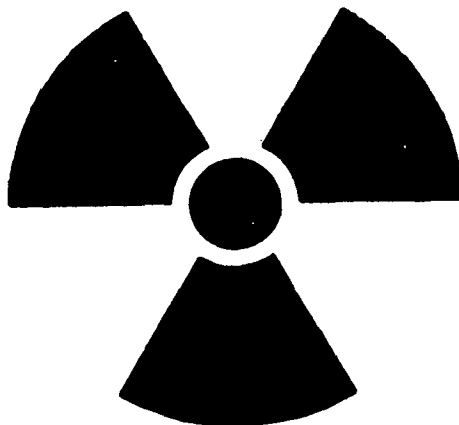

STD-RW-2

Image Intensifier	Th232	Less than 30%	5855-054-8490
-------------------	-------	---------------	---------------

Radiation Hazard Information: The following radiation hazard information must be read and understood by all personnel before operating or repairing Night Vision Sights NA/PVS-3 and AN/PVS-3A. Hazardous radioactive materials are present in the above listed component of the MK-8200/UV.

The components are potentially hazardous when broken. See qualified medical personnel and the local Radiological Protection Officer

(RPO) immediately if you are exposed to or cut by broken components. First aid instructions are contained in TB 43-0122, and AR 755-15.

NEVER place radioactive components in your pocket. Use extreme care NOT to break radioactive components while handling them.

NEVER remove radioactive components from cartons until you are ready to use them.

If any of these components are broken, notify the local RPO immediately. The RPO will survey the immediate area for radiological contamination and will supervise the removal of broken components. The above listed radioactive components will not be repaired or disassembled.

Disposal of broken, unserviceable, or unwanted radioactive components will be accomplished in accordance with the instructions in AR 755-15.

Changes in force: C 1, C 2, C 3, and C 4

TM 11-5855-209-10  
C 4

CHANGE }  
No. 4 }

HEADQUARTERS  
DEPARTMENT OF THE ARMY  
WASHINGTON, D.C., 5 October 1973

**Operator's Manual**  
**NIGHT VISION SIGHT**  
**AN/PVS-3 AND AN/PVS-3A**

TM 11-5855-209-10, 28 December 1967, is changed as follows:

*Page 3, paragraph 1-2b.* Delete the last sentence of subparagraph  
b. Paragraph 1-3. Delete paragraph 1-3 and substitute:

**1-3. Forms and Records**

*a. Reports of Maintenance and Unsatisfactory Equipment.* Maintenance forms, records, and reports which are to be used by maintenance personnel at all maintenance levels are listed in and prescribed by TM 38-750.

*b. Report of Packaging and Handling Deficiencies.* Fill out and forward DD Form 6 (Report of Packaging and Handling Deficiencies) as prescribed in AR 700-58 (Army)/NAVSUP PUB 378 (Navy)/AFR 71-4 (Air Force)/and MCO P4030.29 (Marine Corps).

*c. Discrepancy in Shipment Report (DISREP) (SF 361).* Fill out and forward Discrepancy in Shipment Report (DISREP) (SF 361) as prescribed in AR 55-38 (Army)/NAVSUP PUB 459 (Navy)/AFM 75-34 (Air Force)/and MCO P4610.19 (Marine Corps).

**1-3.1. Recommendations for Equipment Publication Improvements**

The reporting of errors, omissions, and recommendations for improving this publication by the individual user is encouraged. Reports should be submitted on DA Form 2028 (Recommended Changes to Publications) and forwarded direct to Commander, US Army Electronics Command, ATTN: AMSEL-MA-S, Fort Monmouth, NJ 07703.

Page 5. After paragraph 1-6 add:

**1-7. Items Comprising an Operable Night Vision Sight AN/PVS-3 and AN/PVS-3A**

<i>FSN</i>	<i>Qty</i>	<i>Nomenclature, part No., and mfr code</i>
5855-832-9341		Night Vision Sight AN/PVS-3 which includes:
5855-156-4993		Night Vision Sight AN/PVS-3A which includes:

**NOTE**

The part number is followed by the applicable 5-digit Federal supply code for manufacturers (FSCM) identified in SB 708-42 and used to identify manufacturer, distributor, or Government agency, etc.

6140-056-7612	1	Battery Tray Assembly, BA1533 MIL-B-18; 81349
5120-198-5392	1	Socket Key

Page 6, paragraph 2-2a. Delete the third sentence of subparagraph a.

Page 12, paragraph 3-2. Delete the first sentence of paragraph 3-2.

Page 20, appendix B. Delete appendix B and substitute:

**APPENDIX B**

**BASIC ISSUE ITEMS LIST (BIIL) AND ITEMS TROOP INSTALLED OR AUTHORIZED LIST (ITIAL)**

**Section I. INTRODUCTION**

**B-1. Scope**

This appendix lists basic issue items and items troop installed or authorized required by the crew/operator for operation and maintenance of Night Vision Sight AN/PVS-3 and AN/PVS-3A.

**B-2. General**

This Basic Issue Items and Items Troop Installed or Authorized List is divided into the following sections:

a. *Basic Issue Items List—Section II.* A list, in alphabetical sequence, of items which are furnished with, and which must be turned in with the end item.

b. *Items Troop Installed or Authorized List—Section III.* A list, in alphabetical sequence of items which, at the discretion of the

unit commander, may accompany the end item, but are not subject to be turned in with the end item.

### **B-3. Explanation of Columns**

The following provides an explanation of columns found in the tabular listings:

*a. Illustration.* This column is divided as follows:

(1) *Figure number.* Indicates the figure number of the illustration in which the item is shown.

(2) *Item number.* Not applicable.

*b. Federal Stock Number.* Indicates the Federal stock number assigned to the item and will be used for requisitioning purposes.

*c. Part number.* Indicates the primary number used by the manufacturer (individual, company, firm, corporation, or Government activity), which controls the design and characteristics of the item by means of its engineering drawings, specifications standards, and inspection requirements, to identify an item or range of items.

*d. Federal Supply Code for Manufacturer (FSCM).* The FSCM is a 5-digit numeric code used to identify the manufacturer, distributor, or Government agency, etc., and is identified in SB 708-42.

*e. Description.* Indicates the Federal item name and a minimum description required to identify the item.

*f. Unit of Measure (U/M).* Indicates the standard of basic quantity of the listed item as used in performing the actual maintenance function. This measure is expressed by a two-character alphabetical abbreviation, (e.g., ea, in., pr, etc.). When the unit of measure differs from the unit of issue, the lowest unit of issue that will satisfy the required units of measure will be requisitioned.

*g. Quantity Furnished with Equipment (Basic Issue Items Only).* Indicates the quantity of the basic issue item furnished with the equipment.

*h. Quantity Authorized (Items Troop Installed or Authorized Only).* Indicates the quantity of the item authorized to be used with the equipment.

### **B-4. Special Information**

Usable on codes are included in the description column. Uncoded items are applicable to all models. Identification of the usable on codes are as follows:

<i>Code</i>	<i>Used on</i>
1 .....	AN/PVS-3
2 .....	AN/PVS-3A

## Section II. BASIC ISSUE ITEMS LIST

(1) Illustration		(2) Federal stock number	(3) Part number	(4) FSCM	(5) Description  Usable on code	(6) Unit of meas	(7) Qty furn with equip
(A) Fig. No.	(B) Item No.						
4-2.1		5855-245-8443	SC-D-635146	80063	CARRYING CASE	EA	1

## Section III. ITEMS TROOP INSTALLED OR AUTHORIZED LIST

(1) Federal stock number	(2) Part number	(3) FSCM	(4) Description  Usable on code	(5) Unit of meas	(6) Qty auth
8020-409-3000	HB-118	81349	BRUSH, ARTIST TYPE 3CL STYLE C	EA	1
5120-198-5392			SOCKET KEY  2	EA	1

By Order of the Secretary of the Army:

CREIGHTON W. ABRAMS  
*General, United States Army*  
*Chief of Staff*

Official:

VERNE L. BOWERS  
*Major General, United States Army*  
*The Adjutant General*

Distribution:

*Active Army:*

USASA (2)	Instl (2) except
CNGB (1)	Fort Gordon (10)
ACSC-E (2)	Fort Huachuca (10)
Dir of Trans (1)	Fort Carson (15)
COE (1)	Ft Richardson (ECOM) (2)
TSG (1)	WSMR (1)
USAARENBD (1)	Army Dep (2) except
USAMB (10)	LBAD (14)
AMC (1)	SAAD (50)
FORSCOM (5)	TOAD (14)
ARADCOM (2)	ATAD (10)
ARADCOM Rgn (2)	USA Dep (2)
OS Maj Comd (4)	Sig Sec USA Dep (5)
ECOM (25)	Sig Dep (5)
LOGCOMD (3)	Sig FLDMS (2)
MICOM (2)	USAERDAA (1)
TECOM (2)	USAERDAW (1)
USAIB (2)	MAAG (1)
USASTRATCOM (4)	USARMIS (1)
MDW (1)	Units org under fol TOE: (1 cy ea)
Armies (2)	5-25 11-158
7th & 8th USA (10)	5-127 11-215
Corps (2)	5-146 11-216
HISA (ECOM) (21)	5-155 11-500 (AA-AC)
Svc Colleges (1)	5-215 17-35
USASESS (5)	7-15 17-52
USAADS (20)	7-35 17-75
USAFAS (5)	7-45 17-95
USAARMS (50)	7-55 17-105
USAIS (50)	7-102 17-107
USAES (50)	11-35 17-157
USAINTS (2)	11-36 29-16
WRAMC (1)	11-37 29-36
USACDCEC (10)	11-38 29-134
ATS (1)	11-39 29-136
USAIC (10)	11-95 29-137
Night Vis Lab (10)	11-117 57-42

**NG: None**

**USAR: None**

**For explanation of abbreviations used, see AR 310-50.**

**Changes in force: C1, C2, and C3**

**TM 11-5855-209-10  
C 3**

**CHANGE }  
No. 3 }**

**HEADQUARTERS  
DEPARTMENT OF THE ARMY  
WASHINGTON, D.C., 10 February 1972**

**Operator's Manual**

**NIGHT VISION SIGHT AN/PVS-3 AND AN/PVS-3A**

TM 11-5855-209-10, 28 December 1967, is changed as follows:

Add the following WARNING notice inside the front cover:

Check the eyepiece assembly for decal indicating that MWO 11-5800-210-30-1 has been applied. Unmodified night sights present a possible eye hazard during operation and must be returned to Sacramento Army Depot for application of MWO 11-5800-210-30-1.

*Page 4*, paragraph 1-3d, next to last line. Change "AMSEL-  
ME-NMP-EM" to: AMSEL-MA-SNV.

*Page 22*. Delete section II and substitute new section II.

## SECTION II. BASIC ISSUE ITEMS

(1) SMR CODE	(2) FEDERAL STOCK NUMBER	(3) DESCRIPTION  REFERENCE NO.      USABLE ON & MFR. CODE      CODE		(4) UNIT OF MEAS	(5) QTY INC IN UNIT	(6) QTY FURN WITH EQUIP	(7) ILLUSTRATIONS	
							(a) FIG NO.	(b) ITEM NO. OR REFERENCE DESIGNATION
GOS	5855-832-9341	NIGHT VISION	1	ea				
		SIGHT, AN/PVS-3 SC-D- 635200-1; 80063 (With MWO 11-5855-209-30/1 completed)						
GOS	5855-156-4993	NIGHT VISION	2	ea			4-2.1	
		SIGHT, AN/PVS-3A SC-D-635200-2; 80063						
		TECHNICAL MANUAL TM 11-5855-209-10		ea	1	1		
		Requisition through pin- point account number if as- signed; otherwise through nearest Adjutant General fa- cility.						
		A quantity of one technical manual is packed with each equipment. Where a valid need exists, additional copies may be requisitioned and kept on hand.						

(1) SMR CODE	(2) FEDERAL STOCK NUMBER	(3) DESCRIPTION		(4) UNIT OF MEAS	(5) QTY INC IN UNIT	(6) QTY FURN WITH EQUIP	(7) ILLUSTRATIONS	
		REFERENCE NO. & MFR. CODE	USABLE ON CODE				(a) FIG NO.	(b) ITEM NO. OR REFERENCE DESIGNATION
PO	6140-056-7612	BATTERY TRAY	1, 2	ea	1	5	4-2.1	
		ASSEMBLY, BA1533 MIL-						
		B-18; 81349						
PO	8020-409-3000	BRUSH, ARTIST	1, 2	ea	1	1	4-2	
		HB-118, TYPE 3CL STYLE						
		C; 81349						
PO	5120-198-5392	NO ACCESSORIES, TOOLS		ea	1	1	4-2.1	
		OR TEST EQUIPMENT						
		ARE TO BE ISSUED WITH						
		THIS EQUIPMENT						
		NO BASIC ISSUE ITEMS ARE						
		MOUNTED IN OR ON THE						
		EQUIPMENT						

By Order of the Secretary of the Army:

W. C. WESTMORELAND,  
*General, United States Army,*  
*Chief of Staff.*

Official:

VERNE L. BOWERS,  
*Major General, United States Army,*  
*The Adjutant General.*

Distribution:

*Active Army:*

USASA (2)	USAADS (20)
CNGB (1)	USASESS (5)
ACSC-E (2)	USAFAS (5)
Dir of Trans (1)	USAINTS (3)
CofSptS (1)	Army Dep (2) except
COE (1)	SAAD (50)
TSG (1)	LBAD (14)
USAARENBD (2)	TOAD (14)
USAMB (10)	ATAD (10)
USAIB (2)	LEAD (7)
USACDC (2)	NAAD (5)
USACDC Agcy (1) except	SVAD (5)
USACDCIA (2)	Gen Dep (2)
USACDCEC (10)	Sig Sec, Gen Dep (5)
MICOM (4)	Sig Dep (10)
USASTRATCOM (4)	ATS (1)
TECOM (2)	MAAG (1)
USAESC (70)	WRAMC (1)
OS Maj Comd (4)	USAIC (10)
USARV (25)	USAERDAW (5)
LOGCOMD (5)	USAERDAA (2)
CONARC (5)	USACRREL (2)
ARADCOM (2)	USARMIS (1)
ARADCOM Rgn (2)	Sig FLDMS (2)
MDW (1)	Units org under fol TOE:—2 ea.
Armies (2) except	5-12
7th & 8th USA (10)	5-25
Corps (2)	5-137
1st Cav Div (3)	5-146
Instl (2) except	5-155
Ft Carson (21)	5-215
Ft Gordon (10)	7
Ft Huachuca (10)	7-15
WSMR (3)	7-35
Svc Colleges (2)	7-45
USAARMS (50)	7-55
USAIS (50)	7-102
USAES (50)	11-35

11-36	17-75
11-37	17-95
11-38	17-105
11-39	17-107
11-95	17-157
11-117	29-16
11-158	29-36
11-215	29-134
11-216	29-136
11-500(AA-AC)	29-137
17-35	57-42
17-52	

**ARNG & USAR:** None.

**For explanation of abbreviations used, see AR 310-50.**

**Changes in force: C 1 and C 2**

**TM 11-5855-209-10  
C 2**

CHANGE }  
No. 2 }

**HEADQUARTERS  
DEPARTMENT OF THE ARMY  
WASHINGTON, D.C., 9 March 1970**

**Operator's Manual**

**NIGHT VISION SIGHT AN/PVS-3 AND AN/PVS-3A**

TM 11-5855-209-10, 28 December 1967, is changed as follows:  
The title of the manual is changed as shown above (page 1 of C 1).

**NOTE**

The parenthetical reference to a previous change (example: page 1 of C 1) indicates that pertinent material was published in that change.

*Page 2, figure 1-1.* Add to caption "(AN/PVS-3)"

Add figure 1-1.1 after figure 1-1.

*Page 4, paragraph 1-3d,* next to last line. Change "AD" to: EM.

*Page 5, after paragraph 1-5.* Add:

**1-6. Differences in Models**

Night Vision Sight AN/PVS-3A differs from Night Vision Sight AN/PVS-3 in the following details.

a. The cover assembly cap furnished with the AN/PVS-3A replaces the attenuator lens cap described in paragraph 1-4b (1).

b. The eyeshield differs in that it is not molded onto the eye-piece assembly.

c. The AN/PVS-3A has an attached boresight mount and is supplied with two different adapter assemblies for receiver mounting.

*Page 6, paragraph 2-2b(3).* Change to:

(3) Examine the AN/PVS-3 lens cap (AN/PVS-3A cover assembly cap) for rips, dust, or damaged apertures.

*Page 7, after paragraph 2-2b(5).* Add:

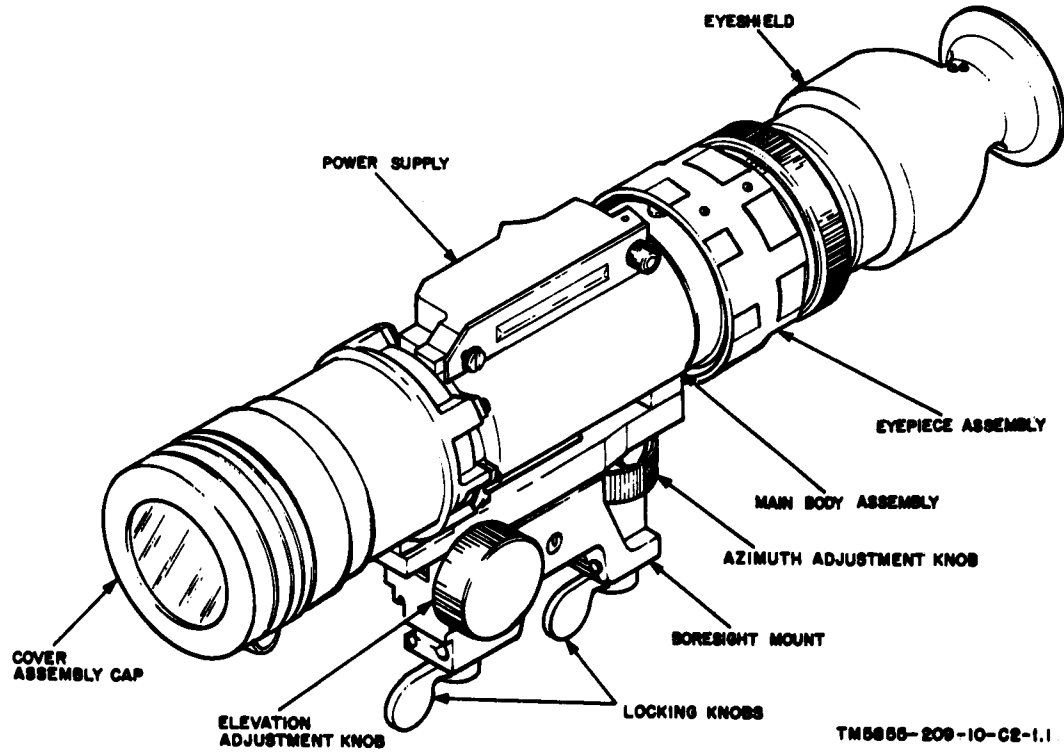

*Figure 1-1.1 Night Sight, front left view (AN/PVS-3A).*

(6) Examine the boresight mount and adapter assemblies for nicks, burs, or cracks.

Paragraph 2-4, heading, add: (AN/PVX-3 Only).

After paragraph 2-4, add:

#### **2-4.1. Installation of Cover Assembly Cap (AN/PVS-3A)** (fig. 2-2.1)

a. Press the cover assembly cap keeper onto the objective lens assembly.

b. Press the cover assembly cap onto the objective lens assembly and insure that a proper seal has been made with the grove on the shade.

#### **NOTE**

The night sight is normally shipped with the cover assembly cap installed.

Page 8, figure 2-2. Change caption to:

*Figure 2-2. Installation of AN/PVS-3 attenuator lens cap.*

Add figure 2-2.1 after figure 2-2.

Paragraph 2-5. Add the following at the bottom of the chart:

Elevation adjustment knob  
(AN/PVS-3A only, fig. 1-1.1).

a. Clockwise rotation moves night sight up.

b. Counterclockwise rotation moves right sight down.

Azimuth adjustment knob  
(AN/PVS-3A only, fig. 1-1.1).

a. Clockwise rotation moves night sight to right.

b. Counterclockwise rotation moves night sight to left.

Paragraph 2-6, Caution. Change to:

#### **CAUTION**

Always use the AN/PVS-3 attenuator lens cap (AN/PVS-3A cover assembly cap, fig. 2-2.1) under daylight condition (fig. 2-2).

Page 9, paragraph 2-7b. Change to:

b. Examine the AN/PVS-3 attenuator lens cap (AN/PVS-3A cover assembly cap) to insure that it is correctly installed in (on) the objective lens assembly.

Add paragraph 2-7.1 after paragraph 2-7.

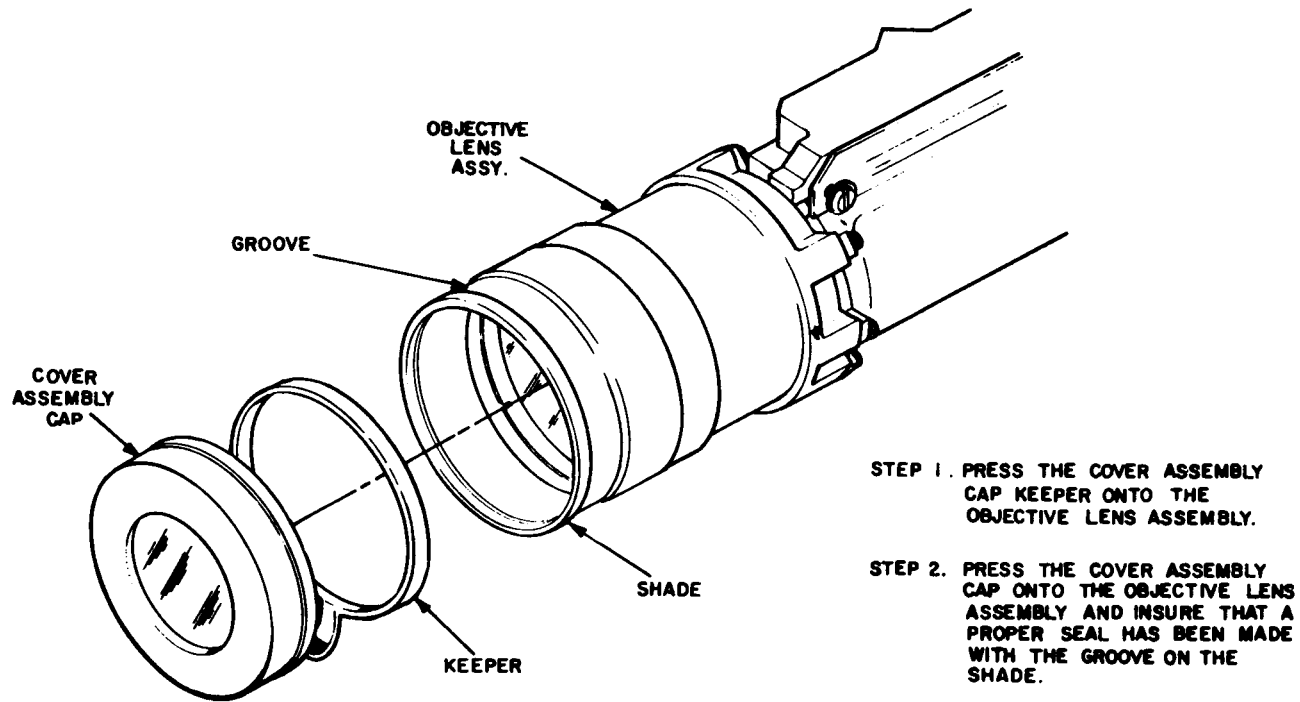

TM5835-209-10-C2-4.1

*Figure 2-2.1. Installation of AN/PVS-3A cover assembly cap.*

## **2-7.1. Mounting AN/PVS-3A on M14 or M16 Rifle** (fig. 4-2.1)

a. Slide the boresight mount forward on the guide rail of the mount assembly until it is positioned against the pin stop of the guide level.

b. Lock the night sight on the mount assembly with the lock knobs (fig. 1-1.1).

After heading of paragraph 2-8, add: (AN/PVS-3).

Add paragraph 2-8.1 after paragraph 2-8.

## **2-8.1. Daylight Operation (AN/PVS-3A)**

### **CAUTION**

Use of the night sight under daylight conditions without the cover assembly cap may damage the light sensitive image intensifier tube.

a. Install the cover assembly cap (fig. 2-2.1).

b. Turn on the night sight (fig. 2-3), and operate as instructed.

*Page 10*, paragraph 2-9, heading. Add: (AN/PVS-3 only).

Add paragraph 2-9.1 after paragraph 2-9.

## **2-9.1. Zeroing Procedure**

a. The night sight may be zeroed during daylight hours or during hours of darkness. However, the operator may experience some difficulty in attempting to zero the night sight just before darkness (dusk). The light level is too low at dusk to permit the operator to resolve his zero target with the lens cap cover in place, but the light level at dusk is still intense enough to cause the night sight to automatically cut off unless the lens cap cover is positioned over the objective lens. The recommended nominal distance for zeroing the night sight, in daylight or at night, is 150 meters.

(1) Place or select a target at the desired zeroing range. Assume a comfortable prone position and support the weapon and night sight combination with sandbags, stakes, or any other available equipment that will afford maximum stability.

(2) Place the reference aiming point on the center of mass of the target, and fire enough rounds to obtain a good shot group

on the target. Check the target to determine the location of the center of the shot group in relation to the point of aim.

(3) Adjust the sight to move the aiming reference point to the center of the shot group. When making adjustments for errors in elevation or azimuth, the sight must be moved in the direction of the error. *For example*, if the shot group is high and to the left of the point of aim, compensate for this error by moving the sight to the left and raising it.

#### NOTE

Each click of the azimuth or elevation knob will move the strike of the round 3 inches at 150 meters.

(4) Repeat the procedures given in (2) and (3) above until the point of aim is alined with the center of the shot group.

b. To engage targets at ranges other than the zero range, the operator must apply *holdoff* to compensate for the rise and fall in the trajectory of the round. -

*Page 11, paragraph 2-11c. Change to:*

c. Keep the carrying case closed and the AN/PVS-3 attenuator cap (AN/PVS-3A cover assembly cap) installed on the objective lens assembly when the night sight is not in use.

*Page 13, paragraph 3-4. Change under "Items to be inspected" to:*

- 3 AN/PVS-3 attenuator lens cap  
(AN/PVS-3A cover assembly cap)

Paragraph 3-4. Add the following to the chart:

- |   |                          |  |   |
|---|--------------------------|--|---|
| 8 | Azimuth adjustment knob. | Rotate azimuth adjustment knob, and see that boresight assembly is adjustable. | Report to higher category of maintenance. |
|---|--------------------------|--|---|

#### NOTE

If the night sight is zeroed to a particular weapon, count the number of clicks, and return the knob to its original setting.

- |   |                            |   |   |
|---|----------------------------|---|---|
| 9 | Elevation adjustment knob. | Rotate elevation adjustment knob, and see that boresight assembly is adjustable. See <i>note</i> above. | Report to higher category of maintenance. |
|---|----------------------------|---|---|

Paragraph 3-5c. Change to:

c. *Rubber Eyeshield and AN/PVS-3 Attenuator Lens Cap (AN/PVS-3A Cover Assembly Cap)*. Clean the rubber eyeshield and AN/PVS-3 attenuator lens cap (AN/PVS-3A cover assembly

cap) with a clean, lint-free, damp cloth to remove dirt. Wipe dry using a dry, clean, lint-free cloth.

*Page 15, paragraph 4-1c. Change to:*

c. Install the AN/PVS-3 attenuator lens cap (AN/PVS-3A cover assembly cap, fig. 2-2.1) on the night sight (fig. 2-2).

Delete paragraphs 4-2 and 4-3 and substitute:

#### **4-2. Storage of Night Sight**

For information on administrative storage of the night sight, refer to TM 740-90-1.

*Page 18. Add figure 4-2.1 after figure 4-2:*

*Page 19. Add:*

TM 740-90-1 Administrative Storage of Equipment

*Page 22, chart, "Section II. Basic Issue Items". Add:*

(AN/PVS-3)

**By Order of the Secretary of the Army :**

**W. C. WESTMORELAND,**  
*General, United States Army,*  
*Chief of Staff.*

**Official :**

**KENNETH G. WICKHAM,**  
*Major General, United States Army,*  
*The Adjutant General.*

CHANGE }  
No. 1 }

HEADQUARTERS  
DEPARTMENT OF THE ARMY  
WASHINGTON, D.C., 24 April 1969

## Operator's Manual

### NIGHT VISION SIGHT, AN/PVS-3

TM 11-5855-209-10, 28 December 1967, is changed as follows:

The title of the manual is changed as shown above.

Page 3, paragraph 1-1, line 1. Delete "Miniaturized".

Page 4, paragraph 1-4c. Delete the last sentence.

Page 5, paragraph 1-5. After "Field of view" add:

Magnification ----- 4X

Page 16, paragraph 4-6a. (2), line 2. Delete "7.62-mm M14 Rifle or 5.56-mm M16 Rifle" and substitute: pistol or service rifle.

Page 20. Delete Appendix B and substitute:

## APPENDIX B

### BASIC ISSUE ITEMS

#### Section I. INTRODUCTION

##### B-1. Scope

This appendix lists items comprising an operable equipment and those required for installation, operation, or operator's maintenance for Night Vision Sight, AN/PVS-3. This appendix is current as of 31 October 1968.

##### B-2. Explanation of Columns

The following is a list of explanations of columns in section II.

a. *Source, Maintenance, and Recoverability Codes (SMR) Column.*

(1) *Source code (S).* The selection status and source for the listed item is the first code indicated in this column. The source code used and its explanation is:

###### Code

P—Applies to repair parts that are stocked in or supplied from GSA/DSA, or Army supply system, and authorized for use at indicated maintenance categories.

(2) *Maintenance code (M).* The lowest category of maintenance authorized to install the item is indicated by the second code in the column. The maintenance category code and its explanation is:

###### Code

O

###### Explanation

Operator/Crew.

(3) *Recoverability code (R)*. The recoverability code is the third code in the column. It indicates whether unserviceable items should be returned for recovery or salvage. Recoverability codes and their explanations are as follows:

*Note.* When no code is indicated in the recoverability column, the part will be considered expendable.

*Code*

*R*—Applies to repair parts and assemblies that are economically repairable at DSU and GSU activities and are normally furnished by supply on an exchange basis.

*b. Federal Stock Number Column.* This column indicates the Federal stock number for the item.

*c. Description Column.* This column includes the Federal item name and any additional description of the item which may be required. A part number or other reference number is followed by the applicable five-digit Federal Supply Code for Manufacturers. Usuable on code column is not used.

*d. Unit of Measure Column.* The unit used as a basis of measure (e.g., ea, pr, ft, yd, etc.) is given in this column.

*e. Quantity Incorporated in Unit Column.* The total quantity of the item used in the equipment is given in this column.

*f. Quantity Furnished with Equipment Column.* This column lists the quantity of the item supplied for initial operation of the equipment and/or the quantities authorized to be kept on hand by the operator for maintenance of the equipment.

*g. Illustrations Column.*

(1) *Figure number (a).* The number of the illustration on which the item is shown is indicated in this column.

(2) *Item No. or reference designation (b).* Not used.

**B-3. Batteries**

Dry batteries shown are used with the equipment but are not considered part of the equipment. They will not be preshipped automatically but are to be requisitioned in quantities necessary for the particular organization in accordance with SB 11-6.

**B-4. Federal Supply Codes**

This paragraph lists the Federal supply code with the associated manufacturer's name.

<i>Code</i>	<i>Manufacturer</i>
37480-----	Machlet Laboratories, Inc., Components Division.
81349-----	Military Specifications.
96906-----	Military Standards.

**SECTION II. BASIC ISSUE ITEMS**

(1) SMR CODE	(2) FEDERAL STOCK NUMBER	(3) DESCRIPTION  Reference Number & Mfr Code	(4) UNIT OF MEAS	(5) QTY INC IN UNIT	(6) QTY FURN WITH EQUIP	(7) ILLUSTRATIONS	
						(a) FIG. NO.	(b) ITEM NO. OR REFERENCE DESIGNATION
P-F-R		NIGHT VISION SIGHT, MINIATURIZED AN/PVS-3; 37480 (This item is nonexpendable)  TECHNICAL MANUAL TM 11-5855-209-10  Requisition through pinpoint account number if assigned; otherwise through nearest Adjutant General facility  A quantity of one technical manual is packed with each equipment. Where a valid need exists, additional copies may be requisitioned and kept on hand.	ea			4-2	
P-O	6135-056-7612	BATTERY ASSEMBLY: SC-D-635072-1; 80063	ea	1	1	4-2	
P-O	8020-409-3000	BRUSH, ARTIST: M-B-118, Type 3CL style G; 81349	ea	1	1	4-2	
P-O	5855-055-1694	CASE, ASSEMBLY, CARRYING: SC-D-635052-1; 80063	ea	1	1	4-2	
P-O	6640-597-6745	PAPER, LENS: MN-P-40; 96906  NO ACCESSORIES, TOOLS, AND TEST EQUIPMENT  NO BASIC ISSUE ITEMS ARE MOUNTED IN OR ON THIS EQUIPMENT	pk	1	1	4-2	

1-B

AN/PVS-3

By Order of the Secretary of the Army:

W. C. WESTMORELAND,  
*General, United States Army,*  
*Chief of Staff.*

Official:

KENNETH G. WICKHAM,  
*Major General, United States Army,*  
*The Adjutant General.*

**Operator's Manual**

**NIGHT VISION SIGHT, MINIATURIZED AN/PVS-3**

		Paragraph	Page
Chapter	1. INTRODUCTION		
Section	I. General		
	Scope-----	1-1	3
	Indexes of publications-----	1-2	3
	Forms and records -----	1-3	3
	II. Description and data		
	Description -----	1-4	4
	Technical characteristics -----	1-5	5
Chapter	2. OPERATING INSTRUCTIONS		
Section	I. Service upon receipt of equipment		
	Unpacking -----	2-1	6
	Inspecting and servicing equipment -----	2-2	6
	Installation of battery tray -----	2-3	7
	Installation of attenuator lens cap-----	2-4	7
	II. Operation under usual conditions		
	Controls and indicators -----	2-5	8
	General operating instructions-----	2-6	8
	Preparation for use-----	2-7	9
	Daylight operation -----	2-8	9
	Nighttime operation -----	2-9	10
	III. Operation under unusual conditions		
	Operation in extreme cold -----	2-10	10
	Operation in dusty or sandy areas-----	2-11	10
	Operation in rainy or humid conditions -----	2-12	11
	Operation in saltwater areas-----	2-13	11
CHAPTER	3. OPERATOR MAINTENANCE		
	Scope of operator's maintenance-----	3-1	12
	Tools, materials, and test equipment -----	3-2	12
	Preventive maintenance-----	3-3	12
	Operator's daily preventive maintenance checks and services chart-----	3-4	13
	Cleaning -----	3-5	13
	Operator's troubleshooting -----	3-6	14
	4. SHIPMENT AND LIMITED STORAGE AND DEMOLITION TO PREVENT ENEMY USE		
Section	I. Shipment and limited storage		
	Preparation for shipment -----	4-1	15
	Preparation for limited storage -----	4-2	15
	Inspection and maintenance of equipment in storage-----	4-3	15

Chapter 4-Continued

Section	II. Demolition of materiel to prevent enemy use	Paragraph	Page
	General .....	4-4	15
	Demolition plan .....	4-5	16
	Methods destruction .....	4-6	16
	Disposal.....	4-7	18
APPENDIX A.	REFERENCES .....		19
	B. BASIC ISSUE ITEMS .....		20

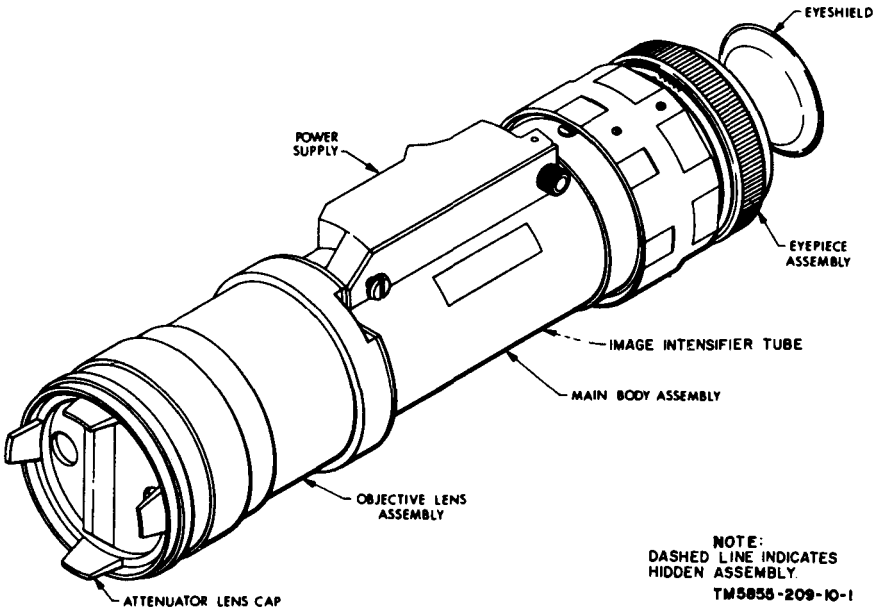

Figure 1-1. Night sight, front left view.

## CHAPTER 1

### INTRODUCTION

---

#### Section I. GENERAL

##### **1-1. Scope**

This manual describes Night Vision Sight, Miniaturized AN/PVS-3 (fig. 4-2) and provides instructions for installation, operation and operator's maintenance. The basic issue items list (BIIL) appears in appendix B.

##### **1-2. Indexes of Publications**

*a. DA Pam 310-4.* Refer to the latest issue of DA Pam 310-4 to determine whether there are new editions changes or additional publications pertaining to the equipment.

*b. DA Pam 310-7.* Refer to DA Pam 310-7 to determine whether there are modification work orders (MWO's) pertaining to the equipment. Department of the Army Pamphlet No. 310-7 lists all authorized Department of the Army modification work orders, identifying the type, model, series, and Federal stock number of the item to be modified; the number, date, and classification of the MWO; the category of maintenance authorized to perform the modification; and the man-hours required to apply the modification to each item.

##### **1-3. Forms and Records**

*a. Reports of Maintenance and Unsatisfactory Equipment.* Use equipment forms and records in accordance with instructions provided in TM 38-750.

*b. Report of Packaging and Handling Deficiencies.* Fill out and forward DD Form 6 (Report of Packaging and Handling Deficiencies) as prescribed in AR 700-58 (Army), NAVSUP Publication 378 (Navy), AFR 71-4 (Air Force), and MCO P4610-5 (Marine Corps).

*c. Discrepancy in Shipment Report (DISREP) (SF361).* Fill out and forward Discrepancy in Shipment Report (DISREP) (SF361) as prescribed in AR 55-38 (Army), NAVSUP Pub 459 (Navy), AFM 75-34 (Air Force), and MCO P4610.19 (Marine Corps).

*d. Reporting of Equipment Manual Improvements.* Report of error omissions and recommendations for improving this publication by the individual user is encouraged. Reports should be submitted on DA Form 2028 (Recommended Changes to DA Publications) and forwarded direct to Commanding General, U.S. Army Electronics Command, ATTN : AMSEL-ME-NMP-AD, Fort Monmouth, N.J. 07703

## **Section II. DESCRIPTION AND DATA**

### **1-4. Description**

*a. General.* Night Vision Sight, Miniaturized AN/PVS-3 is a portable battery-powered, electro-optical instrument used for observing distant objects under conditions of either night or day illumination. The AN/PVS-3 consists of the night sight, a carrying case, and a battery tray. When used at night, the night sight amplifies reflected ambient light, such as moonlight, starlight, or Skyglow so that the object to be viewed becomes clearly visible to the operator. The night sight does not project a visible or infrared light and, therefore, cannot be detected by the enemy.

*b. Night Sight (fig. 1-1).* The night sight consists of a main body assembly which includes the objective lens assembly, eyepiece assembly, image intensifier tube, and power supply. An eyeshield is attached to the eyepiece assembly, and an attenuator lens cap fits on the objective lens assembly.

- (1) The attenuator lens cap reduces the amount of light entering the image intensifier tube during daylight operation.
- (2) The eyeshield aids in security by preventing light leaks on the operator's face caused by visible glow from the eyepiece assembly. Rubber flaps in the eyeshield close completely to prevent light leakage when the operator removes the eyeshield from his eye

*c. Carrying Case (fig. 4-2).* The carrying case provides protection for the night sight during transportation and storage. The case has a belt loop for attachment to the operator's pistol or cartridge belt. A pocket inside the carrying case is provided to store the accessories

*d. Accessories.* A lens brush, lens tissue and a spare battery tray are shipped and stored in the carrying case as accessories to the night sight.

**1-5. Technical Characteristics**

Type -----	Portable, handheld viewing device.
Power source -----	Battery tray (two cell).
Operating conditions -----	Temperature range of -65° F. (-55° C.) to +115°F. (+46° C.). Humidity range of 0 to 100 percent.
Focusing range -----	From 4 meters to infinity.
Field of view -----	10°.
Weight -----	3 pounds (with battery tray installed).
Length -----	13.5 inches.
Width -----	3.5inches.
Battery tray data:	
Battery type-----	Mallory RM-930 (two) .
Voltage-----	2.8 volts dc.
Shelf life-----	9 months.

## CHAPTER 2

### OPERATING INSTRUCTIONS

---

#### Section I. SERVICE UPON RECEIPT OF EQUIPMENT

##### 2-1. Unpacking

*a. General.* The night sight and its accessory items are contained in a carrying case which is packed in a cardboard shipping carton.

*b. Unpacking.* Carefully slit the sealing tape on the top of the carton, and remove the carrying case.

##### 2-2. Inspecting and Servicing Equipment

**Caution: The night sight is a precision electro-optical instrument and must be handled carefully at all times.**

*a. Checking Equipment for Completeness.* Open the carrying case cover, and remove the night sight. Check the contents of the carrying case against the packing slip. If a packing slip is not available check the contents against the basic issue items list ( app. B). Report all discrepancies in accordance with TM 38-750.

**Caution: Do not allow direct rays from the sun or other bright light to enter the objective lens; this may damage the image intensifier tube.**

*Note.* Shortage of any item that does not affect proper functioning of the night sight should not prevent use of the night sight.

*b. Checking Equipment for Damage.* Inspect the night sight for damage incurred during shipment, as indicated below. Report all damaged equipment in accordance with TM 38-750.

- (1) Examine the night sight external parts, surfaces, and threads for cracks, chips, warping, or abrasions. Check to insure that the nameplate and eyepiece vernier are readable.
- (2) Examine the lenses in the eyepiece assembly and objective lens assembly (fig. 1-1 ) for fogginess, condensation, or other signs of moisture.
- (3) Examine the attenuator lens cap for rips, dust, or damaged apertures.

- (4) Examine the carrying case for rips and missing or damaged
- (5) Examine the battery trays for damage.

### 2-3. Installation of Battery Tray

(Fig. 2-1)

**Caution:** Place the power switch in off position (toward objective lens) before installing the battery tray.

- a. Loosen the thumbscrews, and open the battery retainer cover.
- b. Install the battery tray as shown in figure 2-1.
- c. Close the battery retainer cover, and secure thumbscrews firmly to insure a watertight seal.

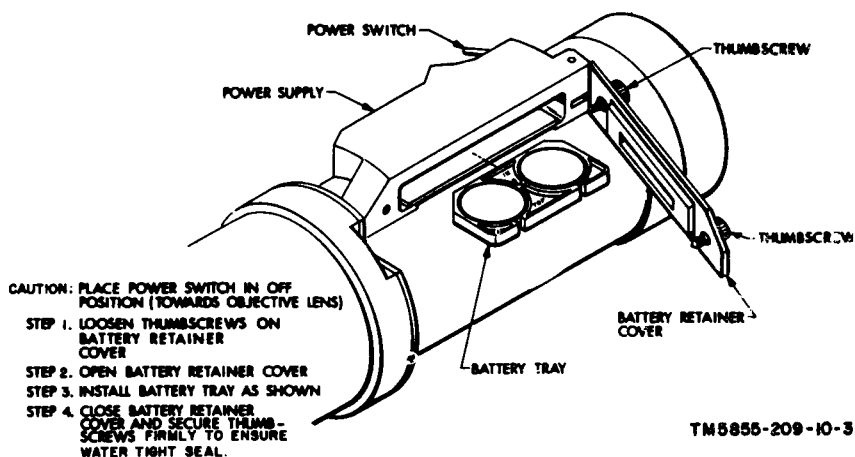

Figure 2-1. Installation of battery tray.

### 2-4. Installation of Attenuator Lens Cap

(Fig. 2-2)

- a. Press the attenuator lens cap into the objective lens assembly. Make sure that the tongue on the lens cap is seated in the objective lens groove.
- b. Rotate the aperture selector to insure that the lens cap is correctly seated in the groove.

*Note.* The night sight is normally shipped with the attenuator lens cap installed.

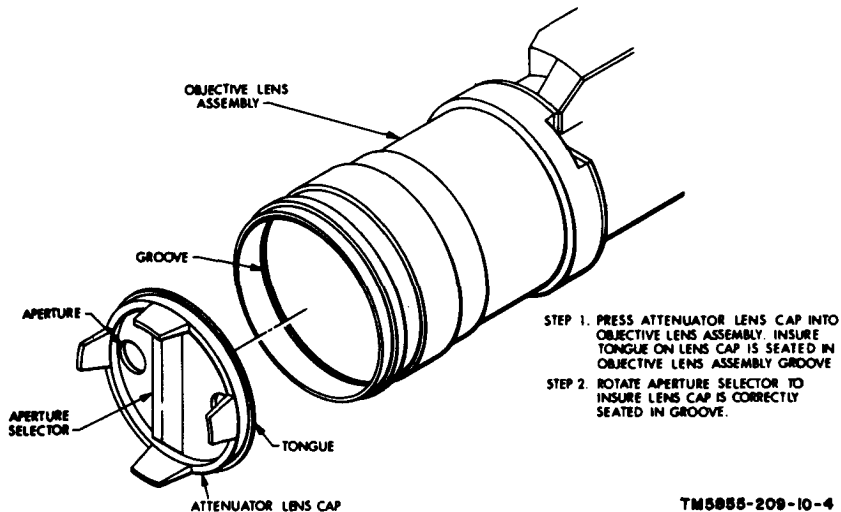

Figure 2-2. Installation of attenuator lens cap.

## Section II. OPERATION UNDER USUAL CONDITIONS

### 2-5. Controls and Indicators

Refer to figure 2-3 for the night sight controls and indicators. The function of the controls and indicators are given in the chart below.

Control	Function
Power switch -----	Turns night sight on and off.
Range focus ring-----	Turns clockwise and counterclockwise to focus image being viewed.
Eyepiece focus ring -----	Turns clockwise and counterclockwise to focus image tube screen.
Eyepiece diopter scale-----	Provides reference points for positioning eyepiece focus ring after best initial focus position has been determined.

### 2-6. General Operating Instructions

(fig. 2-3)

**Caution:** Always use the attenuator lens cap under daylight conditions (fig. 2-2).

- a. Turn on the night sight by pulling the power switch toward the eyepiece.
- b. Press the eye firmly against the eyeshield to open the eyeshield.
- c. Adjust the eyepiece focus ring until a sharp image of the image tube screen is achieved.

**CAUTION:** ALWAYS USE ATTENUATOR LENS CAP UNDER DAYLIGHT CONDITIONS.

- STEP 1. TURN ON NIGHT SIGHT BY PULLING POWER SWITCH LEVER TOWARDS EYEPIECE.
- STEP 2. PRESS THE EYE FIRMLY AGAINST EYESHIELD TO OPEN EYESHIELD.
- STEP 3. ADJUST EYEPIECE FOCUS RING UNTIL SHARP IMAGE OF IMAGE TUBE SCREEN IS ACHIEVED.
- STEP 4. POINT OBJECTIVE LENS AT TARGET AND ADJUST RANGE FOCUS RING FOR SHARP IMAGE.
- STEP 5. READJUST EYEPIECE FOCUS RING TO IMPROVE IMAGE SHARPNESS.

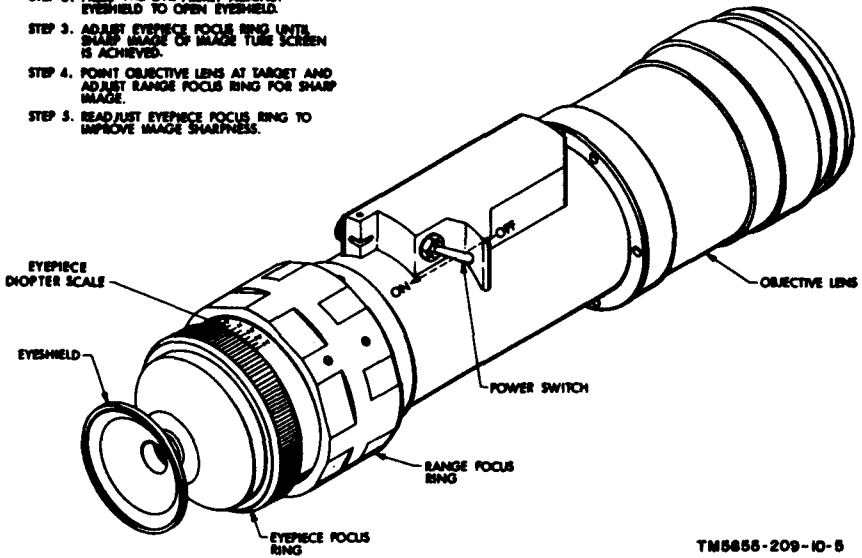

TM5855-209-10-5

Figure 2-3 Location of controls and indicators

d. Point the objective lens at a target, and adjust the range focus ring for a sharp image.

e. Readjust the eyepiece focus ring to improve the image sharpness.

## 2-7. Preparation for Use

Under conditions of foot mobility, the night sight may be stored in the carrying case and attached to the user's belt. The spare battery tray should be checked for satisfactory operation of the night sight.

*Caution:* When inserting the night sight into the carrying case, check to see that the power switch is in the off position.

a. Open the carrying case and check to see that all accessories are stored in the pocket.

b. Examine the attenuator lens cap to insure that it is correctly installed in the objective lens assembly.

c. Install the night sight in the carrying case, objective lens first.

## 2-8. Daylight Operation

*Caution:* Use of the night sight under daylight conditions without the attenuator lens cap may damage the light sensitive image intensifier tube

## TM 11-5855-209-10

- a. Install the attenuator lens cap (fig. 2-2).
- b. Turn the aperture selector on the attenuator lens cap to the smallest aperture position.
- c. Turn on the night sight (fig. 2-3), and operate as instructed.
- d. If the image being viewed is not clearly visible or is not of sufficient brightness, adjust the aperture selector to the next larger aperture.

### 2-9. Nighttime Operation

Under nighttime conditions, the night sight may be operated with or without the attenuator lens cap, depending on the level of illumination. On bright moonlit nights the night sight will operate satisfactorily with the aperture selector on the attenuator lens cap set at the largest aperture. On darker nights when clouds or mist obstruct moonlight or starlight, the night sight is best operated without the attenuator lens cap. Operate the night sight as shown in figure 2-3.

## Section III. OPERATION UNDER UNUSUAL CONDITIONS

### 2-10. Operation in Extreme Cold

a. *Battery Tray Switching.* To extend battery life when using the night sight in temperatures below  $-20^{\circ}$  F. ( $-29^{\circ}$  C.), periodically switch battery trays as follows:

- (1) Keep a battery tray in an inner pocket as close to the body as possible for warmth.
- (2) After approximately 1 hour of operation, switch the battery tray from the night sight with the warmed battery tray.
- (3) Place the removed battery tray in an inner pocket, and repeat the procedure at 1-hour intervals.

b. *Lens Frosting.* Frosting and fogging of the objective and eyepiece lenses may occur in cold weather, and frequent cleaning may be necessary.

### 2-11. Operation in Dusty or Sandy Areas

**Caution: Operation in dusty or sandy areas can cause pitting and scratching of optical elements and damage to mechanical components. Observe the precautions given in *a* through *d* below.**

- a. Avoid pointing the objective lens into the wind unless necessary for operation.
- b. Cover as much of the night sight as possible to prevent damage to external surfaces.

c. Keep the carrying case closed and the attenuator lens cap installed on the objective lens assembly when the night sight is not in use.

d. The objective lens and eyepiece lens require frequent cleaning. To remove dust and sediment from the lenses, use a lens brush. Finish cleaning the lenses with clean lens tissue.

## 2-12. Operation in Rainy or Humid Conditions

a. Close the carrying case to keep the inside of the carrying case dry.

**Caution:** To prevent corrosion or deterioration, thoroughly dry all parts of the night sight after exposure to rain or high humidity.

b. Clean the lenses with dry lens tissue.

c. Wipe the inside of the carrying case with a dry, lint-free cloth.

## 2-13. Operation in Salt Water Areas

a. Close the carrying case to keep the inside of the carrying case dry.

**Caution:** To prevent corrosion, thoroughly clean and dry all parts after exposure to salt water spray conditions.

b. Wet a cloth with fresh water, and wipe the night sight free of salt water residue.

c. Wipe the inside of the carrying case with a wet cloth to remove any salt water residue.

## CHAPTER 3

### OPERATOR MAINTENANCE

---

#### **3-1. Scope of Operator's Maintenance**

The maintenance duties assigned to the operator of the night sight are listed below, together with a reference to the paragraphs covering the specific maintenance duty.

- a. Operator's daily preventive maintenance checks and services (para 3-4).
- b. Cleaning of the night sight and accessories (para 3-5).
- c. Replacing battery tray (fig. 2-1).
- d. Troubleshooting (para 3-6).

#### **3-2. Tools, Materials, and Test Equipment**

Running spares supplied with or issued for use with the night sight are listed in appendix B. The maintenance duties assigned the operator do not require any tools or test equipment; however, a lint-free cloth (FSN 8305-170-5062) is required.

#### **3-3. Preventive Maintenance**

Preventive maintenance is the systematic care, servicing, and inspection of equipment to assure that the equipment is serviceable and to prevent failure during operation.

a. The preventive maintenance checks and services chart (para 3-4) outline functions to be performed at specific intervals. The chart lists what to check and how to check and refers to illustrations, paragraphs, etc., that contain detailed repair or replacement procedures. If the defect cannot be remedied by the operator, a higher category of maintenance or repair is required and the equipment should be forwarded to this maintenance category. Record these checks in accordance with TM 38-750.

b. Preventive maintenance checks and services on the night sight are required daily. Paragraph 3-4 specifies the item to be checked and serviced. In addition to the routine daily checks and services, the night sight should be checked and serviced immediately before and as soon after use as possible.

**3-4. Operator's Daily Preventative Maintenance Checks and Services Chart)**

Sequence No.	Items to be inspected	Procedures	
1	Night sight...	a. Check for complete ness including running spares b. Check for dirt and moisture on external surface and parts.	a. App. B. b. Para 3-5.
2	Crying case	Check for dirt, moisture, and mildew. Service as required.	Para 3-5.
3	Attenuator lens cap.	Check for dirt and moisture. Service as required.	Para 3-5.
4	Controls-----	While performing operating checks (sequence No. 5 through 7), inspect mechanical action of power switch, range focus ring, and eyepiece focus ring for smooth operation, free of binding.	Report to higher category of maintenance if trouble is, noted.
5	Power switch.. -	Place in on position. View through eyepiece, and look for green glow.	Para 3-6.
6	Range focus ring.	Adjust for sharp image se in normal operation.	Report to higher category of maintenance if sharp image cannot be obtained.
7	Eyepiece focus ring.	Adjust for sharp image as in normal operation.	Report to higher category of maintenance if sharp image cannot be obtained.

**3-5. Cleaning**

a. *Glass Suraces.* Clean all exposed lens surfaces as follows:

- (1) Use a clean lens brush to remove all loose dirt from the lens surface.
- (2) Use clean lens tissue saturated with water, and carefully remove stubborn dirt from the lens surface.
- (3) Use clean, dry lens tissue, and wipe the lens surface dry.

b. *Metal Surfaces.* Clean all exposed metal surfaces with a clean cloth. If necessary, dampen the cloth to remove stubborn dirt. Dry the metal surfaces using a clean cloth.

c. *Rubber Eyeshield and Atteuator Lens Cap.* Clean the rubber eyeshield and attenuator lens cap with a clean, lint-free, damp cloth to remove dirt. Wipe dry using dry, clean, lint-free cloth.

## TM 11-5855-209-10

d. Carrying Case. Wipe the inside and outside of the carrying case with a damp cloth. Allow the carrying case to dry thoroughly before using it.

### 3-6. Operator's Troubleshooting

There are no authorized repairs or maintenance adjustments by the operator.

a. Troubleshooting by the operator is limited to the measures indicated in the chart below.

<i>Item No.</i>	<i>Trouble symptom</i>	<i>Probable trouble</i>	<i>Corrective measure</i>
1	Image tube does not show green glow.	Dead batteries, defective power switch, or defective image tube.	Replace dead battery tray. If night sight fails to operate, report to higher category of maintenance.
2	Image being viewed is not clear or bright.	Weak batteries, device out of focus, dirty lens surfaces, or defective image tube.	Replace weak battery tray, and clean lens surfaces. If image does not improve, report to next higher category of maintenance.

b. Battery trays should be disposed of by burying or by dumping them into a large body of water.

**Warning:** The contents of the mercury batteries are extremely irritating to the eyes and oral and nasal tissues; therefore, be careful when discarding the batteries. To prevent explosion, the battery tray *should not be* disposed of by fire.

## CHAPTER 4

### SHIPMENT AND LIMITED STORAGE AND DEMOLITION TO PREVENT ENEMY USE

---

#### Section I. SHIPMENT AND LIMITED STORAGE

##### 4-1. Preparation for Shipment

- a. Perform the daily preventive maintenance checks and services (para 3-4).
- b. Remove the battery tray from the night sight (fig. 2-1).
- c. Install the attenuator lens cap on the night sight (fig. 2-2).
- d. Carefully pack all components in the carrying case (fig. 4-2).

##### 4-2. Preparation for Limited Storage

- a. Perform the daily preventive maintenance checks and services (para 3-4).
- b. Remove the battery tray from the night sight (fig. 2-1).
- c. Install the attenuator lens cap on the night sight (fig. 2-2).
- d. Carefully pack all components, *except* battery trays, into the carrying case (fig. 4-2).
- e. Store the battery trays, if possible, in an area that has a moderate temperature (between 50° F. ( 10° C.) and 80° F. (27° C.)).

##### 4-3. Inspection and Maintenance of Equipment in Storage.

Spot check equipment in storage to insure that it is free from condensation and fungus. When the spot check indicates that condensation or fungus is present, check all stored equipment; clean equipment as required (para 3-5).

#### Section II. DEMOLITION OF MATERIEL TO PREVENT ENEMY USE

##### 4-4. General

The demolition procedures given in paragraph 4-6 should be used to destroy the equipment or render it inoperative. Paragraph 4-5 gives the order of priority for demolition of the equipment and repair parts

## TM 11-5855-209-10

The explosive method of destruction (para 4-6b) should be used where time is not a factor; small arms fire (para 4-6a) should be used where time is a limiting factor.

*Note.* Demolition procedures will not be initiated except upon order of the commander.

### 4-5. Demolition Plan

The following order of priority should be followed for demolition of the night sight:

**Warning:** *The* image intensifier tube phosphor screens contain toxic materials. Avoid inhalation of this material, and do not allow it to come in contact with the mouth or open skin wounds

a. Image intensifier tube.

*Note.* The image intensifier tube must be destroyed to a degree that will prevent duplication.

b. Objective lens assembly.

c. Eyepiece assembly.

d. Main body.

e. Miscellaneous repair parts.

f. Technical manuals.

g. Accessory items.

h. Carrying Case.

### 4-6. Method of Destruction

a. *Small Arms Fire.*

**Warning:** *Be careful when using small arms fire. Glass and metal fragments may spray back in the direction of the person firing.*

(1) Place the night sight against a sandbag, mound of dirt, or other suitable object so that the night sight is resting with a side facing the operator.

(2) At a distance of approximately 1 meter, fire rounds from a 7.62-mm M14 Rifle or 5.56-mm M16 Rifle into the points on the night sight designated by the squares indicated in figure 4-1. The numbers in the squares indicate the order in which the rounds should be fired.

b. *Explosives.*

**Warning:** *Be extremely careful when using explosives for demolition.*

(1) Fasten an M26 Fragmentation Grenade between points 2 and 8 shown in figure 4-1.

(2) Firmly attach the night sight and grenade to stakes, a tree trunk other suitable object.

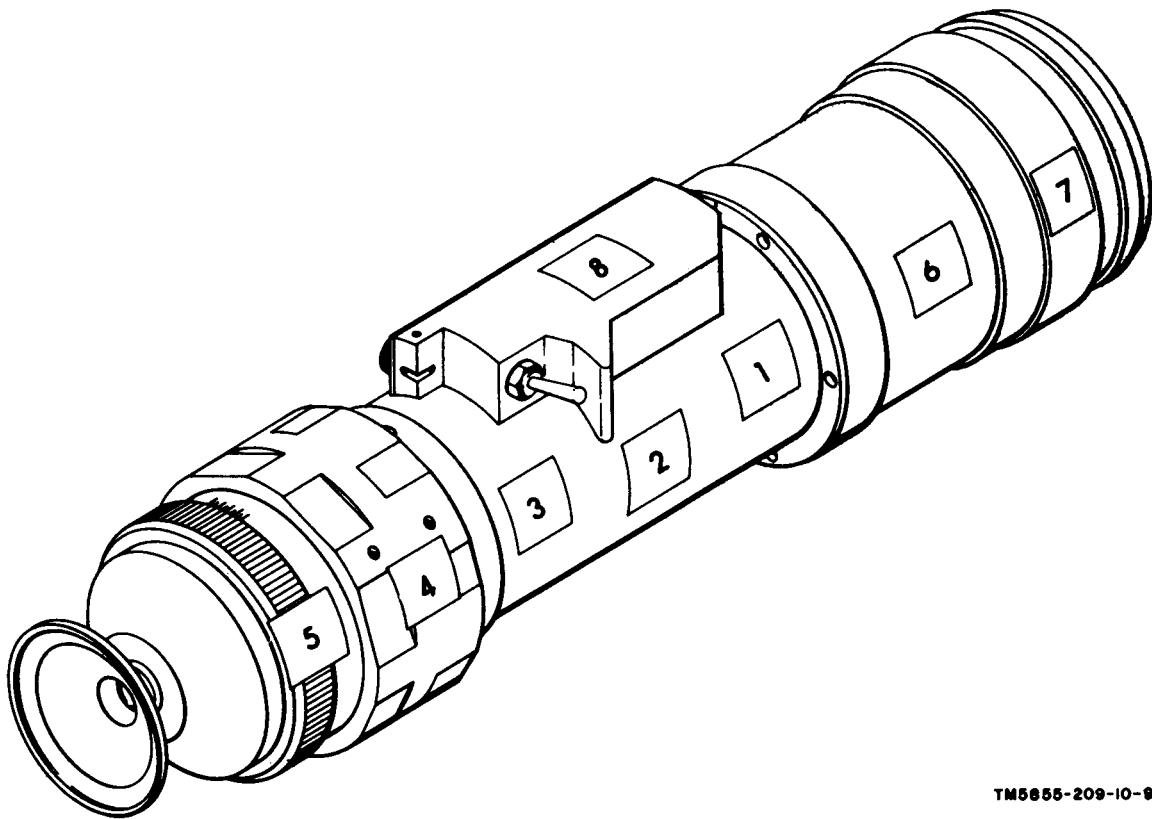

TM5855-209-10-9

*Figure 4-1. Night sight marked for demolition.*

## TM 11-5855-209-10

(3) Remotely detonate the grenade from a safe location

*c. Mechanical.*

Note. This method of destruction should be used on the night sight only when the methods described in a and b above cannot be used. If this method is used, thoroughly dispose of the destroyed parts (para 4-7).

- (1) Use a suitable heavy object to smash the night sight at the points indicated on figure 4-1.
- (2) Smash the accessory items and carrying case.

### 4-7. Disposal

**Warning: The image intensifier tube phosphor screens contain toxic material. Avoid inhalation of the phosphor screen material, and do not allow it to come in contact with the mouth or open skin wounds.**

Throw destroyed parts and miscellaneous repair parts into nearby walkways or bury or scatter the parts if there are no nearby waterways.

## APPENDIX A

### REFERENCES

---

- DA Pam 310-4 ----- Index of Technical manuals, Technical Bulletins, Supply Manuals (types 7, 8, and 9), Supply Bulletins, and Lubrication Orders.
- DA Pam 310-7 ----- U.S. Army Equipment Index of Modification Work Orders.
- TM 38-750----- Army Equipment Record Procedures.

## APPENDIX B

### BASIC ISSUE ITEMS

---

#### Section I. INTRODUCTION

##### B-1. Scope

This appendix lists items comprising an operable equipment and those required for installation, operation, or operator's maintenance for Night Vision, Sight, Miniaturized AN/PVS-3.

##### B-2. Explanation of Columns

The following is a list of explanations of columns in section II.

*a. Source, Maintenance, and Recoverability Codes (SMR) Column.*  
The SMR codes used in this list are-

- (1) *Source code (S).* The selection status and source for the listed item is the first code indicated in this column. The source code used and its explanation is:

<i>Code</i>	<i>Explanation</i>
P-----	Applies to repair parts that are stocked in or supplied from GSA/DSA, or Army Supply system, and authorized for use at indicated maintenance categories.

- (2) *Maintenance code (M).* The lowest category of maintenance authorized to install the item is indicated by the second code in the column. The maintenance category codes and their explanations are:

<i>Code</i>	<i>Explanation</i>
O-----	Organizational Maintenance.
F-----	Direct Support Maintenance.

- (3) *Recoverability code (R).* The recoverability code is the third code in the column. It indicates whether unserviceable items should be returned for recovery or salvage. Recoverability code and its explanation is as follows:

*Note:* When no code is indicated in the recoverability column, the part will be considered expendable.

<i>Code</i>	<i>Explanation</i>
R-----	Applies to repair parts and assemblies that are economically repairable at DSU and GSU activities and are normally furnished by supply on an exchange basis.

*b. Federal Stock Number Column.* This column indicates the Federal stock number for the item.

*c. Description Column.* This column includes the Federal item name and any additional description of the item which maybe required. A part number or other reference number is followed by the applicable five-digit Federal supply code for manufacturers. Usable on code column is not used.

*d. Unit of Issue Column.* The unit used as a basis of issue (e.g., ea, pr, ft, yd, etc.) is given in this column.

*e. Quantity Incorporated in Unit Pack Column.* Not used.

*f. Qwantity Incorporated in Unit Column.* The total quantity of the item used in the equipment is given in this column.

*g. Quantity Furnished With Equipment Column.* This column lists the quantity of the item supplied for initial operation of the equipment and/or the quantities authorized to be kept on hand by the operator for maintenance of the equipment.

*h. Quantity Authorized Column.* Not used.

*i. Illustration (a).*

(1) *Figure number (a).* The number of the illustration in which the item is shown is indicated in this column.

(2) *Item No. or reference designation (b).* Not used.

### **B-3. Batteries**

Dry batteries shown are used with the equipment but are not considered part of the equipment. They will not be preshipped automatically but are to be requisitioned in quantities necessary for the particular organization in accordance with SB 11-6.

### **B-4. Federal Supply Codes**

This paragraph lists the Federal supply code with the associated manufacturer's name.

<i>Code</i>	<i>Manufacturer</i>
12705 . . . . .	Electro-Optical Systems Inc.
37480-----	Machlet Labratories, Inc., Components Division
81349 . . . . .	Military Specifications
96906-----	Military Standards

## SECTION II. BASIC ISSUE ITEMS

(1) SNR CODE	(2) FEDERAL STOCK NUMBER	(3) DESCRIPTION  Reference Number & Mfr Code  USABLE ON CODE	(4) UNIT OF ISSUE	(5) QTY INC IN UNIT PACK	(6) QTY INC IN UNIT	(7) QTY FURN WITH EQUIP	(8) QTY AUTH	(9) ILLUSTRATIONS	
								(a) FIG. NO.	(b) ITEM NO. OR REFERENCE DESIGNATION
P-F-R		NIGHT VISION SIGHT, MINIATURIZED AN/PVB-3: 37480(This item is nonexpendable)	ea					4-2	
		TECHNICAL MANUAL TM 11-5855-209-10  Requisition through pinpoint account number if assigned; otherwise through nearest Adjutant General facility.  NOTE: A quantity of one technical manual is packed with each equipment. Where a valid need exists, additional copies may be requisitioned and kept on hand.	ea		1	1			
P-O		BATTERY ASSEMBLY: 1122101; 12705	ea		1	2		4-2	
P-O	8020-409-3000	BRUSH, ARTIST: H-B-118; Type 3CL style C; 81349	ea		1	1		4-2	
P-O		CASE, ASSEMBLY, CARRYING: 1122125; 12705	ea		1	1		4-2	
P-O	6640-597-6745	PAPER, LENS: NNN-P-40; 96906  NO ACCESSORIES, TOOLS, AND TEST EQUIPMENT  NO BASIC ISSUE ITEMS ARE MOUNTED IN OR ON THIS EQUIPMENT	pk		1	1		4-2	

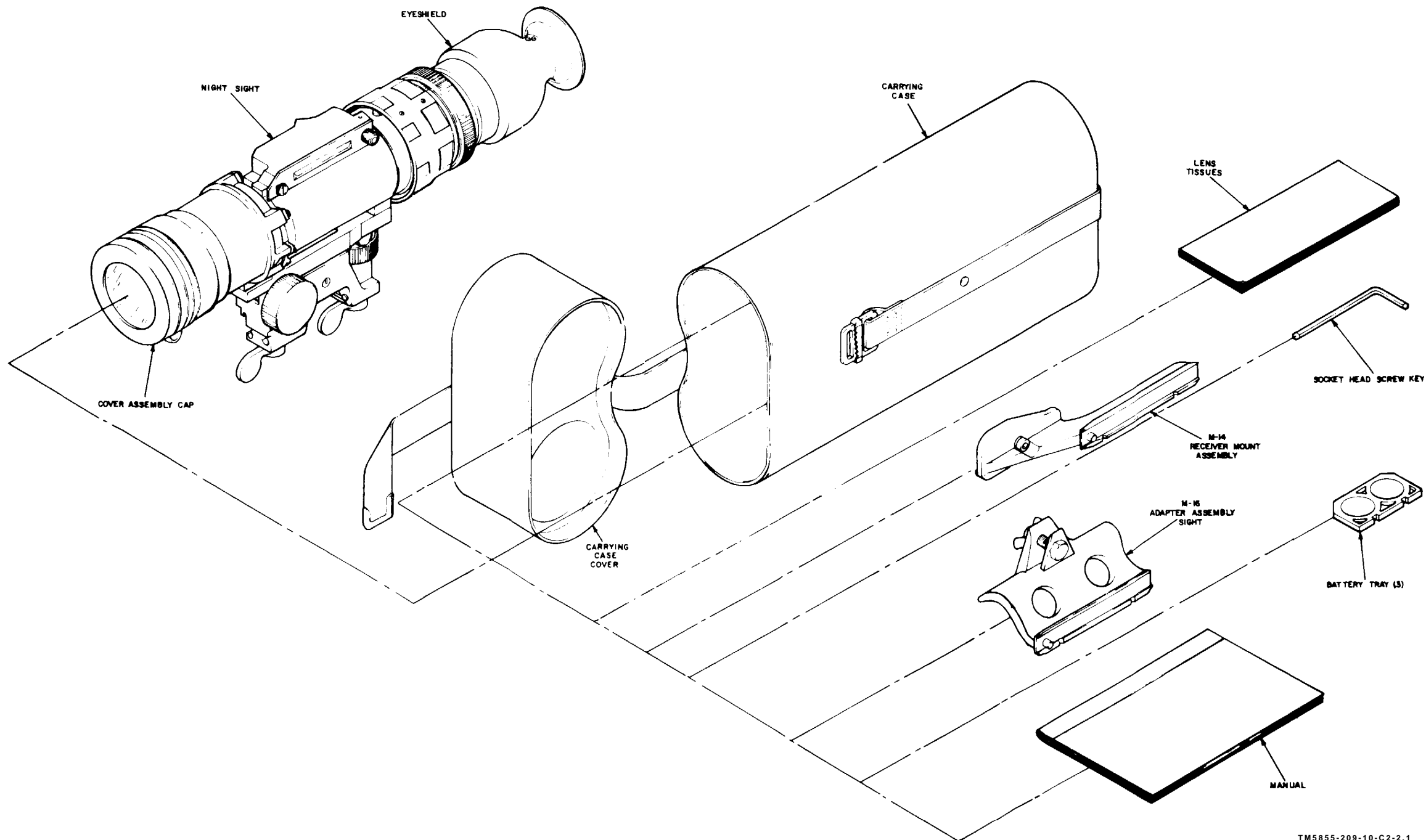

By Order of the Secretary of the Army:

HAROLD K. JOHNSON,  
*General, United States Army,*  
*Chief of Staff.*

Official:

KENNETH G. WICKHAM,  
*Major General, United States Army,*  
*The Adjutant General.*

RECOMMENDED CHANGES TO EQUIPMENT TECHNICAL PUBLICATIONS



THEN...JOT DOWN THE DOPE ABOUT IT ON THIS FORM. CAREFULLY TEAR IT OUT, FOLD IT AND DROP IT IN THE MAIL.

SOMETHING WRONG WITH PUBLICATION

FROM: (PRINT YOUR UNIT'S COMPLETE ADDRESS)

DATE SENT

PUBLICATION NUMBER

PUBLICATION DATE

PUBLICATION TITLE

BE EXACT PIN-POINT WHERE IT IS

PAGE NO.

PARA-GRAPH

FIGURE NO.

TABLE NO.

IN THIS SPACE, TELL WHAT IS WRONG AND WHAT SHOULD BE DONE ABOUT IT.

TEAR ALONG PERFORATED LINE

PRINTED NAME, GRADE OR TITLE AND TELEPHONE NUMBER

SIGN HERE

# THE METRIC SYSTEM AND EQUIVALENTS

## LENGTH MEASURE

1 Centimeter = 10 Millimeters = 0.01 Meters = 0.3937 Inches  
 1 Meter = 100 Centimeters = 1000 Millimeters = 39.37 Inches  
 1 Kilometer = 1000 Meters = 0.621 Miles

## WEIGHTS

1 Gram = 0.001 Kilograms = 1000 Milligrams = 0.035 Ounces  
 1 Kilogram = 1000 Grams = 2.2 lb.  
 1 Metric Ton = 1000 Kilograms = 1 Megagram = 1.1 Short Tons

## LIQUID MEASURE

1 Milliliter = 0.001 Liters = 0.0338 Fluid Ounces  
 1 Liter = 1000 Milliliters = 33.82 Fluid Ounces

## SQUARE MEASURE

1 Sq. Centimeter = 100 Sq. Millimeters = 0.155 Sq. Inches  
 1 Sq. Meter = 10,000 Sq. Centimeters = 10.76 Sq. Feet  
 1 Sq. Kilometer = 1,000,000 Sq. Meters = 0.386 Sq. Miles

## CUBIC MEASURE

1 Cu. Centimeter = 1000 Cu. Millimeters = 0.06 Cu. Inches  
 1 Cu. Meter = 1,000,000 Cu. Centimeters = 35.31 Cu. Feet

## TEMPERATURE

$5/9(^{\circ}\text{F} - 32) = ^{\circ}\text{C}$   
 212° Fahrenheit is equivalent to 100° Celsius  
 90° Fahrenheit is equivalent to 32.2° Celsius  
 32° Fahrenheit is equivalent to 0° Celsius  
 $9/5^{\circ}\text{C} + 32 = ^{\circ}\text{F}$

## APPROXIMATE CONVERSION FACTORS

TO CHANGE	TO	MULTIPLY BY
Inches	Centimeters	2.540
Feet	Meters	0.305
Yards	Meters	0.914
Miles	Kilometers	1.609
Square Inches	Square Centimeters	6.451
Square Feet	Square Meters	0.093
Square Yards	Square Meters	0.836
Square Miles	Square Kilometers	2.590
Acres	Square Hectometers	0.405
Cubic Feet	Cubic Meters	0.028
Cubic Yards	Cubic Meters	0.765
Fluid Ounces	Milliliters	29.573
its	Liters	0.473
arts	Liters	0.946
allons	Liters	3.785
Ounces	Grams	28.349
Pounds	Kilograms	0.454
Short Tons	Metric Tons	0.907
Pound-Feet	Newton-Meters	1.356
Pounds per Square Inch	Kilopascals	6.895
Miles per Gallon	Kilometers per Liter	0.425
Miles per Hour	Kilometers per Hour	1.609

TO CHANGE	TO	MULTIPLY BY
Centimeters	Inches	0.394
Meters	Feet	3.280
Meters	Yards	1.094
Kilometers	Miles	0.621
Square Centimeters	Square Inches	0.155
Square Meters	Square Feet	10.764
Square Meters	Square Yards	1.196
Square Kilometers	Square Miles	0.386
Square Hectometers	Acres	2.471
Cubic Meters	Cubic Feet	35.315
Cubic Meters	Cubic Yards	1.308
Milliliters	Fluid Ounces	0.034
Liters	Pints	2.113
Liters	Quarts	1.057
ers	Gallons	0.264
ms	Ounces	0.035
ograms	Pounds	2.205
Metric Tons	Short Tons	1.102
Newton-Meters	Pounds-Feet	0.738
Kilopascals	Pounds per Square Inch	0.145
ometers per Liter	Miles per Gallon	2.354
ometers per Hour	Miles per Hour	0.621

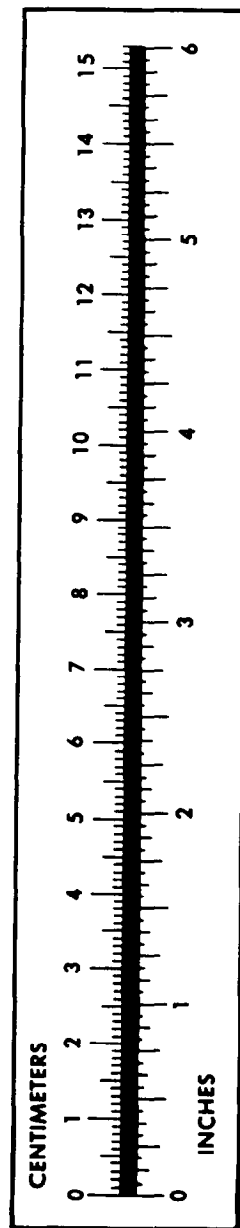

**PIN: 018620-005**