

TDv 5855/013-13

Parts 1 to 3

Bildverstärker-Zeilfernrohr

Für Handwaffen FERO-Z51 ZUB

- **ORION 80I**
- **ORION 80II**

DSK: H5001004429

Weitergabe sowie vervielfältigung dieser Unterlage, Verwertung und Mitteilung ihres Inhalts sind nur mit ausdrücklicher Zustimmung der Bundesrepublik Deutschland zulässig.

Zu widerhandlung verpflichten zum Schadenersatz.

TDv5855/013-13

TDv5855/013-13

VS-NUR FÜR DEN DIENSTGEBRAUCH

TDv 5855/011-13

Part 1 Description

Part 2 Care and Operation

Part 3 Maintenance and Repair by Troops

Bildverstärker-Zeilfernrohr

Für Handwaffen FERO-Z51 ZUB

- **ORION 80I**
- **ORION 80II**

April 1994

Revised 2004

This Manual applies to:

Versorgungsartikelbezeichnung (Article Description)	Versorgungsnummer (Supply Number)
FERNROHRGERÄTSATZ, ZIEL- (ORION 80 I)	5855-12-166-5705
FERNROHRGERÄTSATZ, ZIEL- (ORION 80 II)	5855-12-330-9130

DSK: H5001004429

TDv5855/013-13

MATERIALAMT DES HEERES

54783 Bad Neuenahr-Ahrweiler 1,

Der Leiter

den 13. April 1994

Die Herausgabe der Teile

Part 1 Description

Part 2 Care and Operation

Part 3 Maintenance and Repair by Troops

für

Bildverstärker-Zeilfernrohr Für Handwaffen

FERO-Z51 ZUB

als TDv 5855/013-13

wird genehmigt.

Die TDv 5855/013-13 Ausgabe März 1993 wird heirmit ausser Kraft gesetzt.

Krauss

Brigadegeneral

**Weitergabe sowie vervielfältigung dieser Unterlage,
Verwertung und Mit-teilung uhres Inhalts sind nur mit
ausdrücklicher Genehmigung der Bundesrepublik
Deutschland zulässig.**

Zuwiderhandlung verpflichten zum Schadenersatz.

Vorbemerkung

- 1. In this TDv, parts 1 to 3 are included in this one volume.**
- 2. The Orion 80II differs from the Orion 80I most obviously by the shorter middle section, the less sensitive tube and the new lens cap.**
- 3. Knowledge of this device is required to:**
 - correctly handle, operate, maintain, care for and repair,
 - safely function and use the device,
 - ensure a long service life.

Regular technical review, care and maintenance saves expensive repairs.

- 4. Photo numbers and location numbers in the text are given in brackets. For example (5 / 4) means: Figure 5, area number 4**

5. Important instructions to be emphasized:

CAUTION: The operating procedures listed are to be followed precisely, to prevent hazards to yourself or others.

ACHTUNG: To prevent damage to equipment or the night vision device, follow instructions and heed warnings precisely.

NOTE: Some technical aspects of operation require particular attention.

- 6. The work position catalog serves to record all occurring work and determine its type, complexity, time to complete, and material maintenance steps. Any work is provided with a work position number (ArbPosNr) also.**

The principle or organization of the work position catalog corresponds to the equipment breakdown plan of TDv part 5.

Example of work number 541716BO

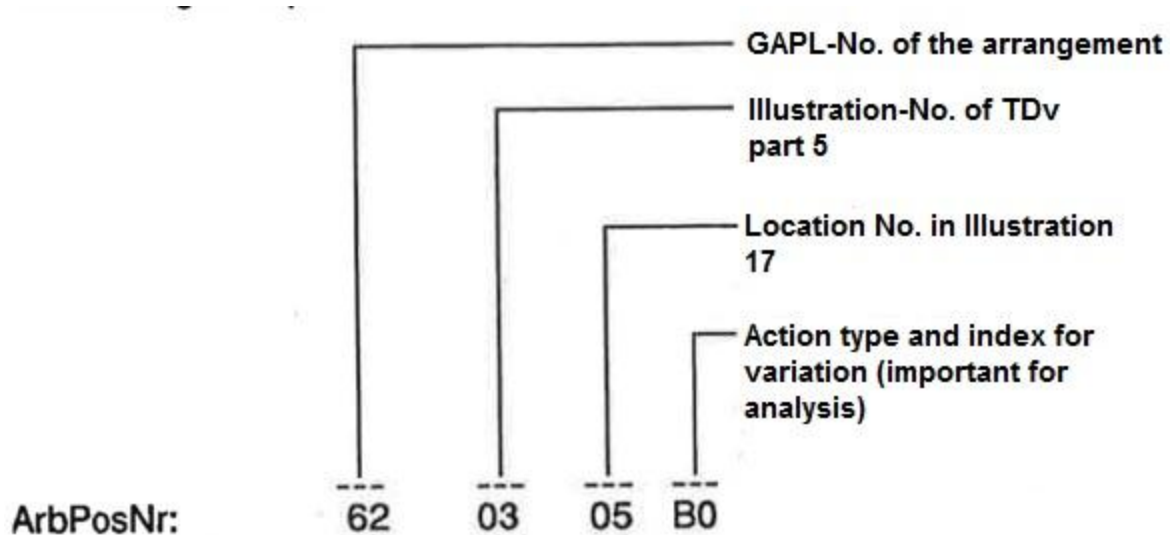

-Work Position

Description of completed work.

-Variation

A difference which exists in the same nature of work and requires a change in time or scope of the work.

-Field of Study

Gives the labor that the corresponding work position shall perform.

-Level of Material Maintenance

The level that the work position is assigned.

-Work Value

Time needed to complete the work position under normal circumstances. (1 work value is equal to 6 minutes)

7. Proposed changes or additions should be submitted to the Material Office of the Army through military channels.

8. Additions and alterations are certified in the Certificate at the end of this manual.

TDv5855/013-13

**Die durchgeführten Änderungen sind im Blatt
"Änderungsnachweis," zu bescheinigen.**

Vorschrittenübersicht

Für das Bildverstärker-Zielfernrohr

für Handwaffen gelten folgende technische

Dienstvorschriften :

**TDv 5855/013-40 (F) Teil 4 (F) Festinstand
setzung**

TDv 5855/013-50 Teil S Ersatzteilkatalog

TDv 4940/003-13 Abschnitt A WSA

Optronik

- Allgemeines

- Einbausatz

TDv 4940/003-13 Abschnitt B Optische Bank

M5 und

Aufbauten

TDv 4940/003-13 Abschnitt C Stromversorgungs und

Prüfanlage (SpA) BM 8027

TDv 4940/003-13 Abschnitt D Luminotest

BM BO29

TDv 4940/003-13 Abschnitt H Stickstoffspülgerät

LHT-211-011A

TDv 4940/003-13 Abschnitt I Dichtigkeitsprüfgerät

sK 4370

TDv5855/013-13

Table of Contents

Part 1: Description

1.1 GENERAL DATA

- 1.1.1 Nomenclature**
- 1.1.2 Purpose**
- 1.1.3 Identification**
- 1.1.4 Night Vision Scope Construction**

1.2 TECHNICAL DATA

- 1.2.1 Size and weight**
- 1.2.2 Performance Data**
- 1.2.3 Electrical Data**
- 1.2.4 Optical Data**

1.3 TECHNICAL DESCRIPTION

- 1.3.1 General**
- 1.3.2 Optical and electrical Construction**
- 1.3.3 Mechanical Construction**
 - 1.3.3.1 Objective Group**
 - 1.3.3.2 Connecting Group**
 - 1.3.3.3 Ocular Group**
- 1.3.4 Reticle Group**
- 1.3.5 Method of Operation**

1.4 EQUIPMENT

- 1.4.1 Storage Case ORION 80 I**
- 1.4.2 Accessories and Spare Parts, ORION 80 I**
- 1.4.3 Storage Case ORION 80 II**

TDv5855/013-13

TDv5855/013-13

Teil 1 Beschreibung

TDv5855/013-13

General Data



Bild 1 Gesamtbild ORION 80 I



Bild 2 Gesamtbild ORION 80 II

1.1.1 Nomenclature

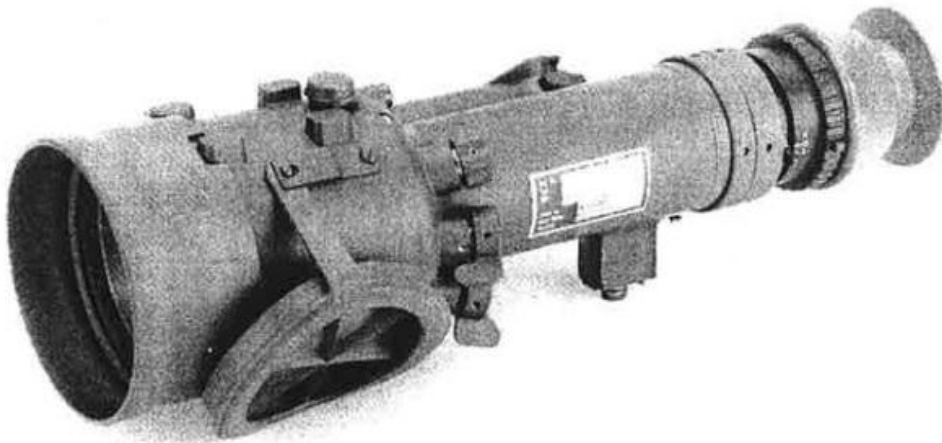
Device	Supply Article Designation	Supply number
Orion 80 I	Fernrohrgeraetesatz, Ziel (ORION 80 I)	5855-1 2-1 66-5705
Orion 80 II	Fernrohrgeraetesatz, Ziel (ORION 80 II)	5855-1 2-330-91 30

Gebrauchsname:

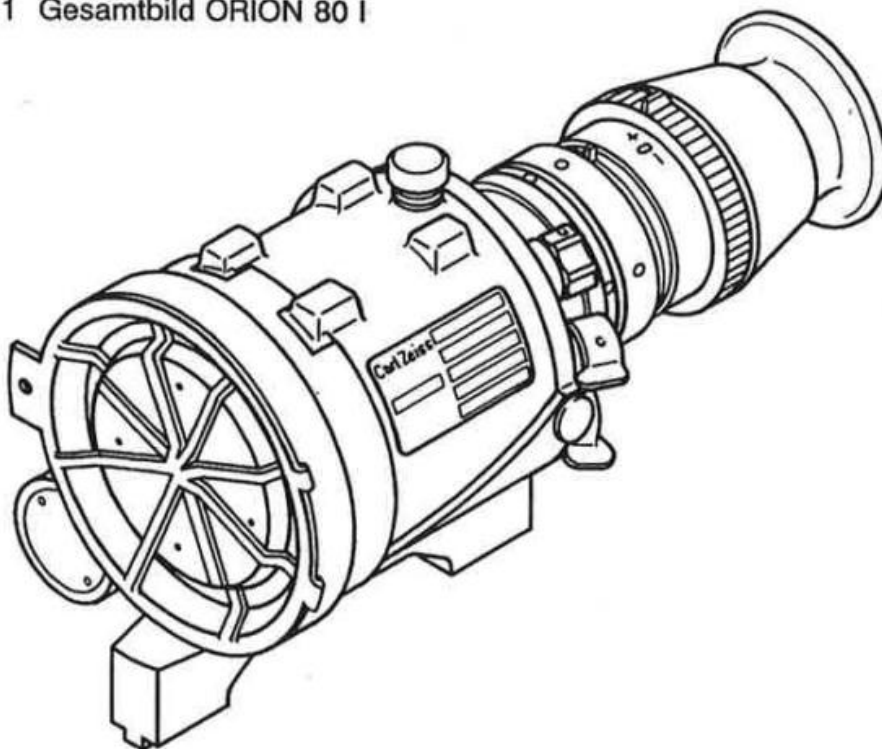
BiV-Zielfernrohr für Handwaffen, FER0-ZS1 ZUB

Geräteschlüsselzahl

348100

1.1.2Purpose

The Orion 80 (Fig. 1 and 2, above) can be used on the weapons:

-G3 Rifle (Fig. 3)

-Machine Gun MG3 with Lafette (Fig. 4)

- Panzerfaust 44 Lanze (Fig 5)

Panzerfaust 3 (Fig 6)

Attached via the corresponding mount assembly-as illustrated in figures 21-25.

The device can be used for observation and targeting during twilight and night operations, without illuminating the target with artificial light sources.



Bild 3 BiV-Zielfernrohr auf Gewehr G3



Bild 4 BiV-Zielfernrohr auf Lafette mit MG

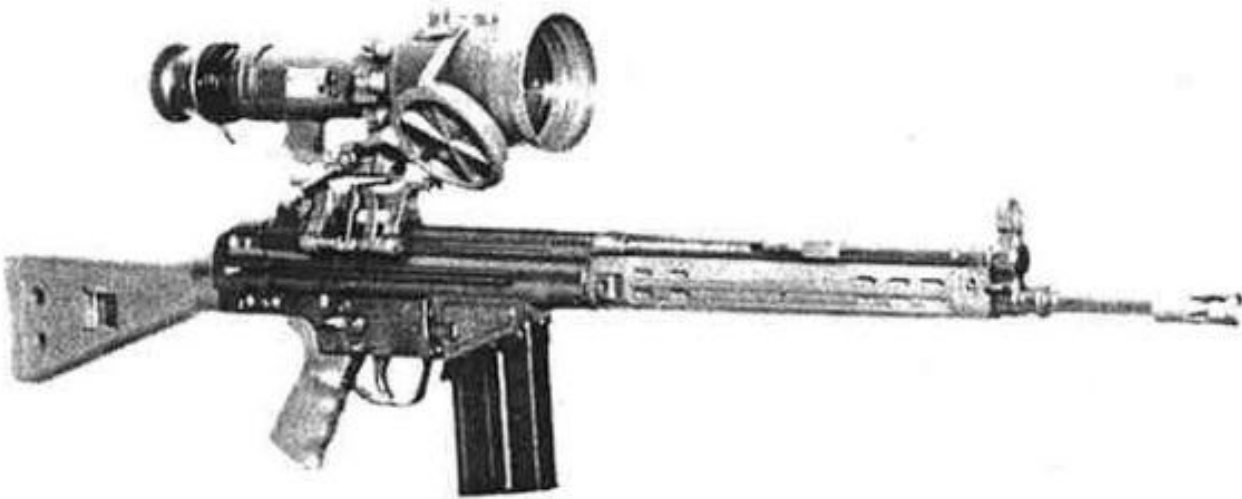

Bild 5 BiV-Zielfernrohr auf Abschußgerät, Granate 44 mm



Bild 6 BiV-Zielfernrohr auf Panzerfaust 3

1.1.3 Identification

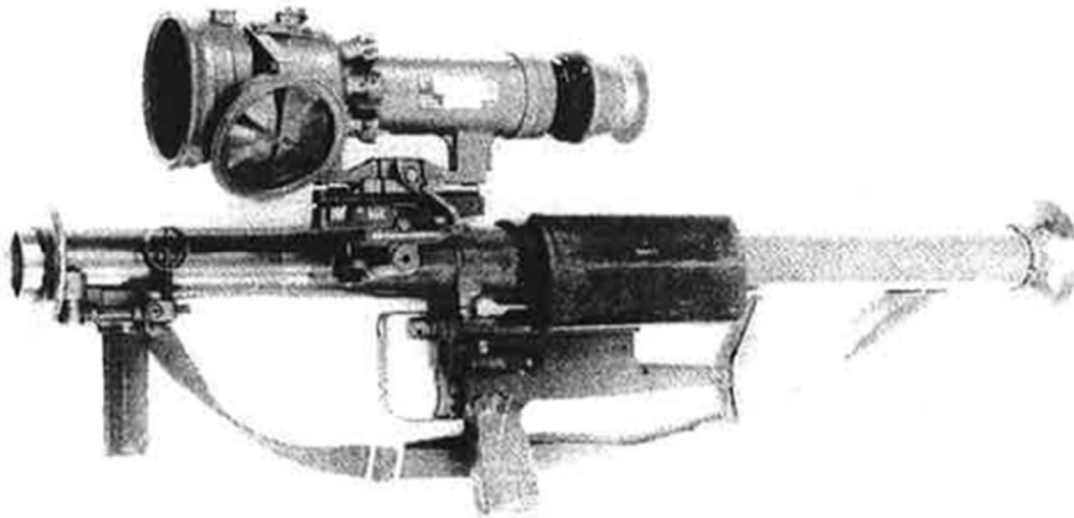
Attached to the left side of either device is a dataplate with the following information.

Vers. Nr.	5855 - 12 - 166 - 5706
Typ	FERO - Z 51
VAN	FERNROHR. ZIEL-, BILDVERSTAERKUNG
Serien Nr.	
Herst. Datum	

Bild 7 Typschild ORION 80 I

An der linken Seite des ORION 80 II (Bild 2) ist auf der Ausblick-
baugruppe ein Typschild mit folgenden Angaben angebracht:

Vers. Nr.	5855-12-330-9403
Typ	BIV ZIELFERNROHR FER0-Z 51
	ORION 80 II
	BUND
Serien Nr.	
Herst. Datum	
Hensoldt	D 1728

Bild 8 Typschild ORION 80 II

1.1.4 Construction of the Night Vision Telescope

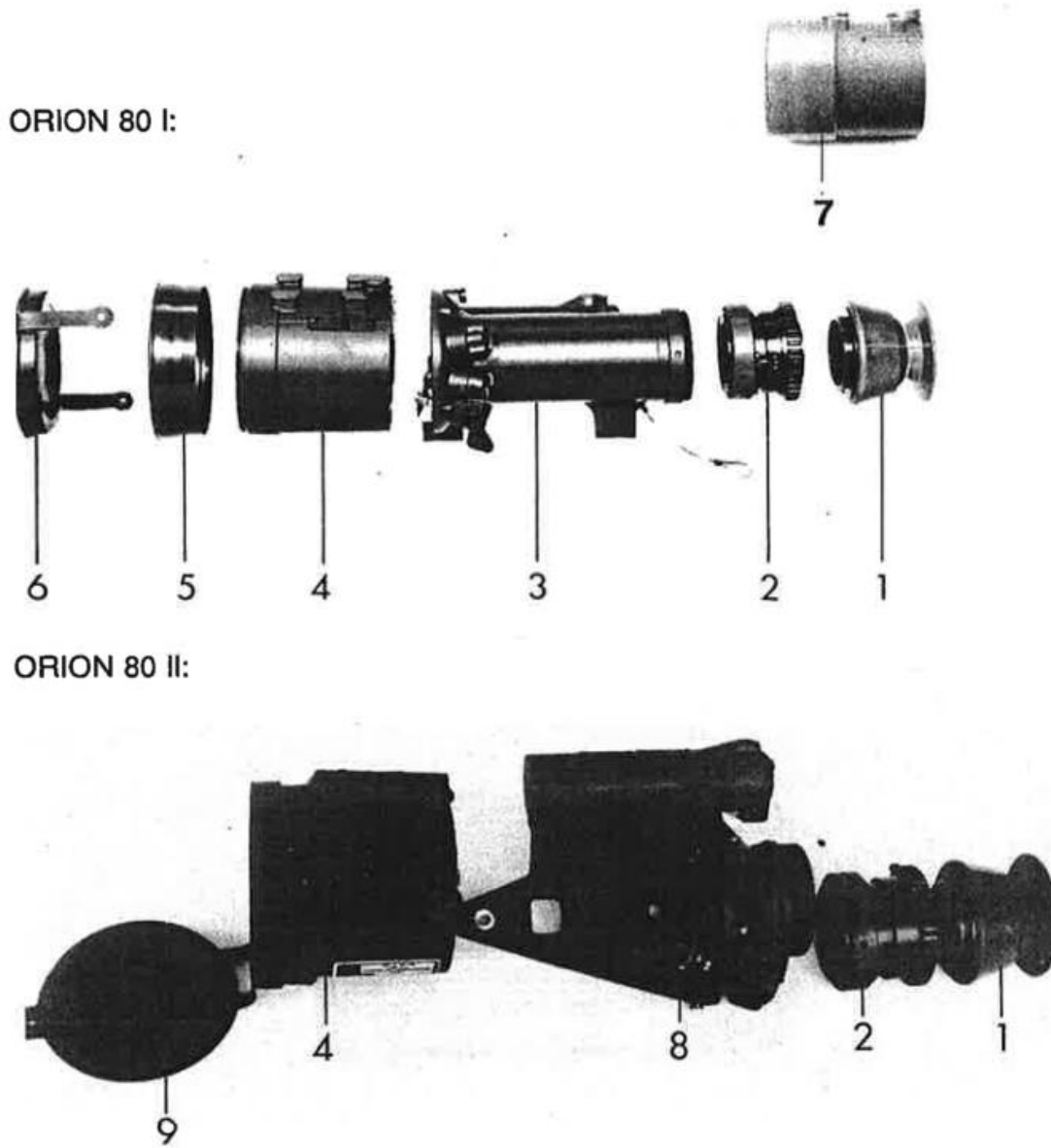

Figure 9 Construction of the Night Vision Sight

1. Eye cup
2. Ocular Group
3. Middle Group (Orion 80 I)
4. Objective Group
5. Protective Cover
6. Lens Cap (Orion 80 I)
7. Viewing module with protective cover
8. Middle Group (Orion 80 II)
9. Lens Cap (Orion 80 II)

The unit consists of:

Eyecup (9 / 1), with a chain attaching it to the Middle Group.

It is mounted on the ocular assembly.

Ocular Group (9 / 2), which is attached to the Middle Group with a threaded retaining ring.

Middle Group (9 / 3) of ORION 80 I or

Middle Group (9 / 8) of Orion 80 II.

Contains the illumination intensifier tubes and a battery tube for 2 batteries. Also includes the device controls.

Objective Group (9 / 4 or 917), which is flanged to the Middle group.

Protective Cover (9 / 5) (only ORION 80 I)

Lens cap (9 / 6) of ORION 80 I or

Lens cap (9 / 9) of ORION 80 II

1.2 Technical Data

1.2.1 Size and Weight

	<u>ORION 80 I</u>	<u>ORION 80 II</u>
Night Vision Device Length.....	345mm	... 250mm
Biggest diameter with Protective Cover and Lens Cap.....	100mm	... 104mm
Weight.....	1,9kg	approx. 1,8kg

Storage Container

Length.....	470mm	... 470mm
Width.....	390mm	... 390mm
Height.....	240mm	... 240mm
Weight with polyurethane foam.....	10,6kg	approx. 7,2kg
Weight with polyethylene foam....	ca. 7,0kg	

Accessories Weight.....	2,5kg	approx. 2,7kg
-------------------------	-------	---------------

Service Kit in containers with holders

Weight with polyurethane foam.....	15kg	
Weight with polyethylene foam...approx.	11,5kg	... 11,7kg

1.2.2 Performance Data

ORION 80 I

ORION 80 II

Temperature Range

Continuous Operation..... -40° to +40° C ... -40° to +40° C

Short-Term Operation (60s Max) -40° to +50° C... -40° to +50° C

Storage temp. (in case)..... -55° to +50° C...-55° to +50° C

Operating time at medium Reticle

illumination at 20° C..... ≥ 25h ≥ 30h

Max Illumination with attenuation

Filter on and lens cap in place 10⁶ lx 10⁶ lx

Max Illumination with attenuation

Filter on and lens cap gone.... 10³ lx 10³ lx

Max Illumination with attenuation

Filter off and lens cap off..... 10 lx 10 lx

Waterproof in Fresh and salt water... DIN 58390-80-02-1

1.2.3 Electrical Data

	<u>ORION 80 I</u>	<u>ORION 80 II</u>
Supply Voltage.....	2,2 to 3,15V ...	2,2 to 3,15V
Electricity Supply.....	2 Batteries ...	2 Batteries
.....	VG95230 T07 .	VG95230 T07
Rated Voltage/Cells.....	1,24 V ...	1,24 V
Capacity.....	1,5 Ah ...	1,5 Ah
Or 2 Dry cells (C-cell).....	BA 42 VG 95233	
Rated Voltage/Cells.....	1,5 V ...	1,5 V
Capacity.....	1,5 Ah ...	1,5 Ah
Input Voltage		
Image Intensifier Tube.....	2,75 V	2,75 V
Luminescent Diode for Reticle.....	2,75V =max	2,75V =max
Image intensifier tube, 3 part... Type XX1211		
	and Type XX1340	
Image Intensifier tube, 1 part.....	Type	
XXI440CJ		

1.2.4 Optical Data

	<u>ORION 80 I</u>	<u>ORION 80 II</u>
Total Magnification.....	4x	5,5x
Diameter of Objective opening.....	80mm	80mm
Aperture Ratio.....	1: 1,65	1: 1,65
Focal Length.....	125mm	125mm
Ocular Opening (apparent).....	≥ 6mm	≥ 6mm
Gap of ocular opening from last ocular lens vertex.....	≥ 20m	≥ 20m
Focus Adjustment.....	approx. 20m to infinity	
Field of View.....	8° (140m at 1000m)	
Field of view at $3 \cdot 10^{-3}$ lux (Clear night against NATO target)...	≥ 350m	≥ 500m
Ocular Adjustment.....	± 5 diopters ...	± 4 diopters
Resolution (optical center).....	0,25 mils	0,25 mils
Range of adjustment of sight marks (windage and elevation).....	± 5 mils	± 5 mils
Smallest adjustment of sight marks....	± 0,5 mils .	± 0,5 mils
Magnifier.....	f =22,5mm ...	f =22,5mm

1.3 Technical Description

1.3.1 General

The Night Vision sight operates on the principle of light amplification. It does not need artificial light sources to illuminate for observation. All targets, which are very dimly lit, for example through starry skies, moonlight etc. and which are invisible or poorly visible to the human eye, are made visible on the screen of the scope.

Under clear night conditions, the resolution of the night vision telescope provides the following values:

Distance from observer	Sideways distance of objects
100m	2.5cm
200m	5.0cm
300m	7.5cm

This means, for example, that two objects which are 300m away from the observer have a distance of 7.5cm from each other (from the observer's point of view) can still be recognized as two separate objects by the Night Vision Device.

Environmental conditions such as fog, rain or snowfall, just as during the day to the unaided eye, impair the perceived range and contrast.

NOTE The figure shows the ORION 80 I. The ORiON 80 II differs only in the length of the image intensifier tube (10 / 8).

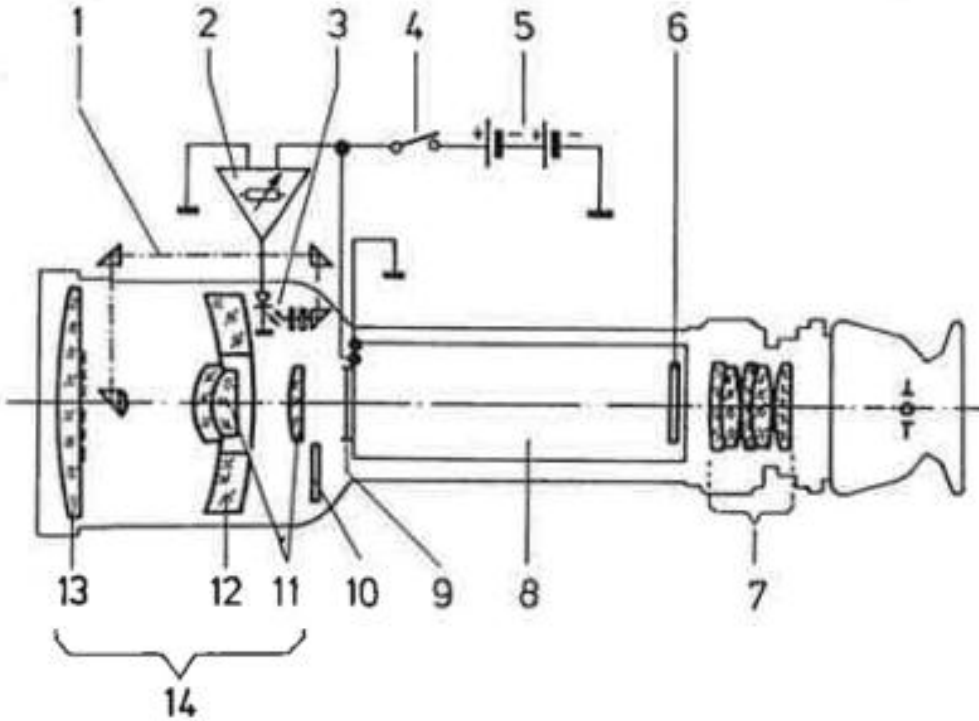

Figure 10 Optical and Electrical Construction

1. Sight mark mirror system
2. Sight mark brightness regulator
3. Light emitting Diode
4. On/Off switch
5. Power supply
6. Fluoroscope
7. Ocular
8. Image Intensifier
9. Photo cathode
10. Attenuation filter
11. Correcting system
12. Concave mirror
13. Front lens
14. Objective

1.3.3 Mechanical Construction

1.3.3.1 Objective Group

The objective (10/14) consists of the front lens (10/13) with a partially reflective rear side, the concave mirror (10/12), the two lens correcting system (10/11), and the sight mark adjustment knobs for elevation (11/4) and windage (8/1), as well as the Protective cover (11/9, only ORION 80 I) and the lens cap (11/8).

On the Orion 80 I, there are two types of protective cover:

Older version, which is screwed on

New version, which is glued

The Orion 80 II eliminates this protective cover, the lens cover is glued on.

The objective group (9/4) is flange mounted to the middle group (9/3) with 5 Allen head screws (11/2).

NOTE Shown is the ORION 80 I. The view of the assembly ORION 80 II differs by the lack of protective cover (11 / 8) and the modified lens cap (see Figure 2).

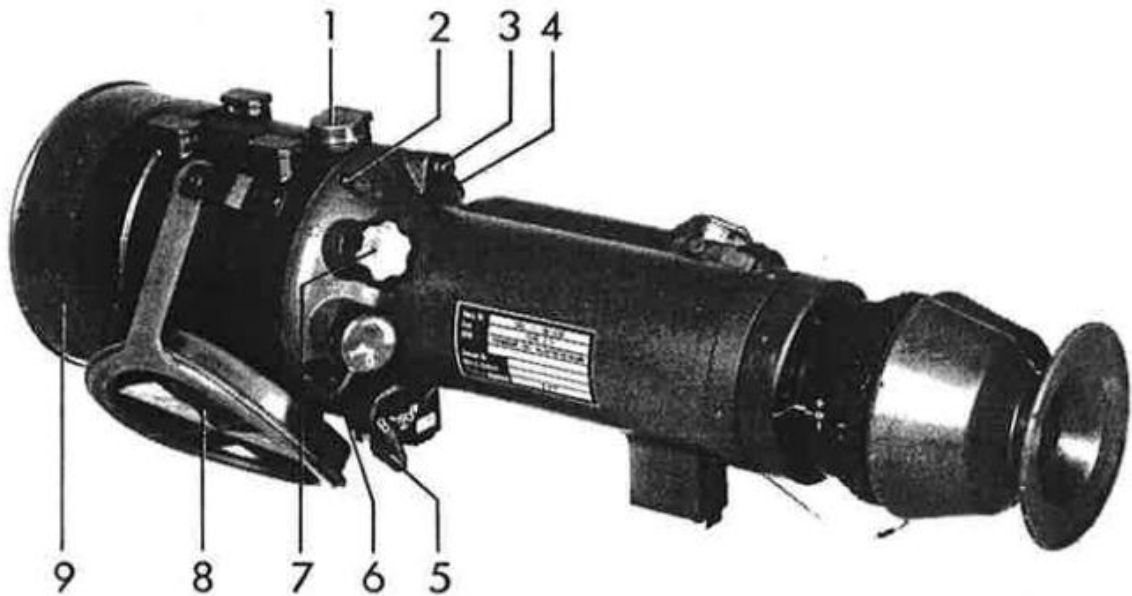

Figure 11 Mechanical construction of the Objective Group

1. Windage Adjustment
2. Allen Head Screw
3. Connection for waterproof testing device
4. Elevation adjustment
5. Focus adjustment
6. On/Off switch and filter adjustment
7. Reticle Brightness Adjustment
8. Lens cap
9. Protective cover

1.3.3.2 Middle Group

NOTE: ORION 80 I and II differ mainly in the Device's midsection. By using a new image intensifier tube, the overall length was reduced significantly. The connector for the waterproof test is in different locations on each device.

The Middle Group (9/3) contains the image intensifier tube (9/8) with the high voltage section. On the right side of the unit (as you would look through it) is the battery tube (12/2), cover (12/5) and Lock (12/4) for mounting two batteries to the device.

On the boundary to the objective group is the device switch (11/6), and the knobs to adjust focus (11/5) and reticle brightness (11/7).

The device switch (11/6) toggles the image intensifier tube on/off and moves the attenuated filter (8/10) into or out of the optical path.

The rotary knob for focus (11/5) enables the adjustment of target distance from 20m to infinity.

The knob for the reticle's Brightness (11/7) serves to adjust the sight illumination.

With both mounts (12/12) the distances are standardized to STANAG 2324 measurements.

ORION 80 I:

The connection to the waterproof test (12/1) is located at the boundary to the objective group.

ORION 80 II:

The connection to the waterproof test (12/13) is located on the underside of the rear seat for clamp (12/12).

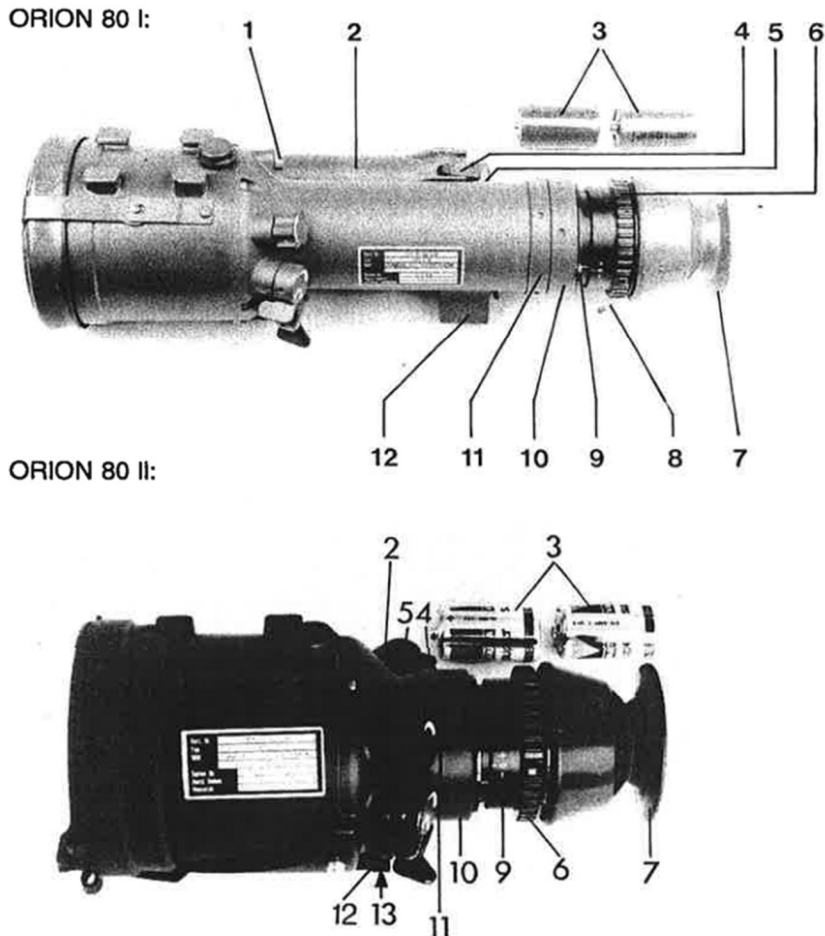

Figure 12 Mechanical Constuction Middle and Ocular Groups

1. Waterproof test connector
2. Battery tube
3. Batteries
4. Lock
5. Battery Tube Cover
6. Diopter Adjustment ring
7. Eye cup
8. Cable
9. Center Mark (diopter=0)
10. Threaded collar ring
11. Threaded counter ring
12. Mount for clamp

1.3.3.3 Ocular Group

The screen image of the intensifier tube is viewed through the five lens ocular (10/7). The knurled diopter adjustment ring (12/6) contains an adjustment range of ± 5 diopters. Two opposing key marks (12/9) indicate the zero-diopter setting. The ocular group attaches to the middle group with a threaded collar ring(12/10), which is tightened by the threaded counter ring (12/11).

The eye cup (12/7) is pushed onto the ocular group. It is secured against loss with an attached cable (12/8).

In the eye cup are two protective flaps that open when pressure is placed against the eye cup, and close when it is removed.

1.3.4 ORION 80 I Reticle

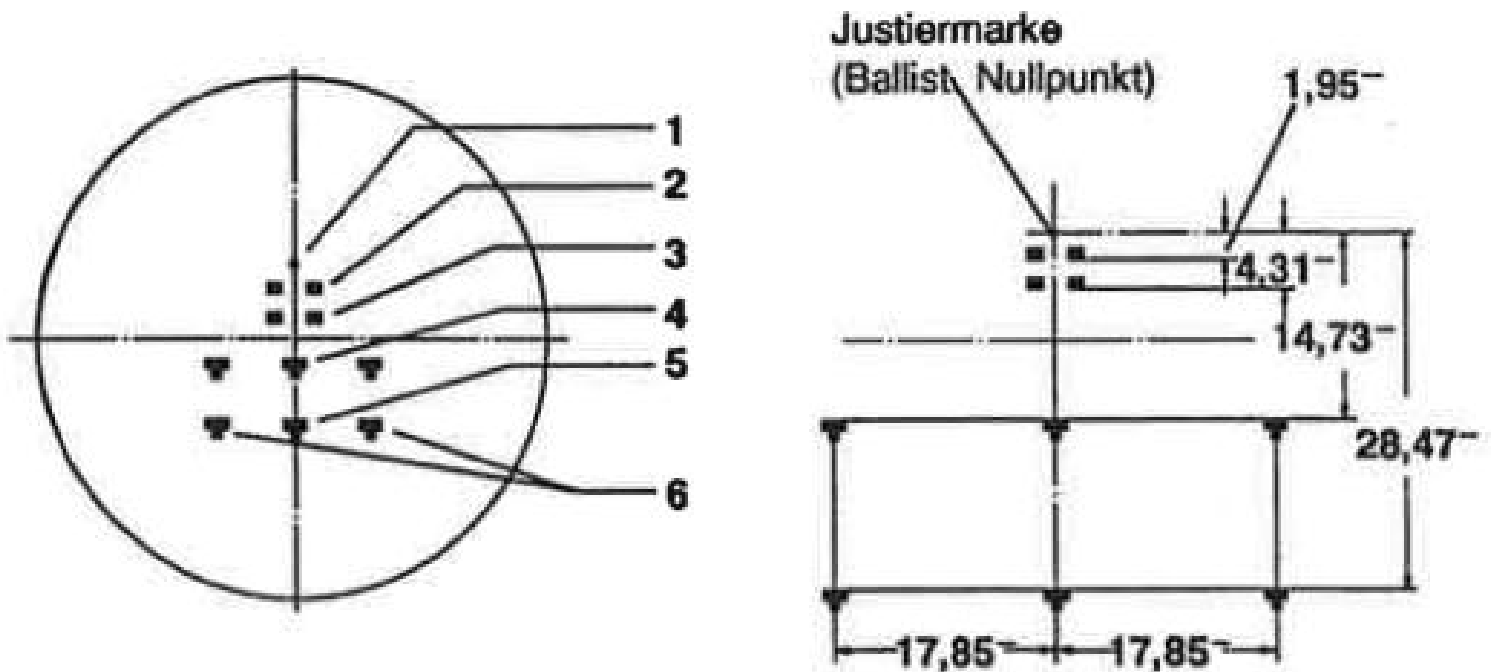

Figure 13 Reticle and Dimensions

1. Ballistic Zero

2. 200m G3 and MG3

**3. 400m G3
500m MG3**

**4. 900m MG3
100m Pzf 44**

**5. 200m Pzf 44
100m Pzf 3**

6. Lead marks for Pzf 44, corresponds to vehicle speed of 18 km/h

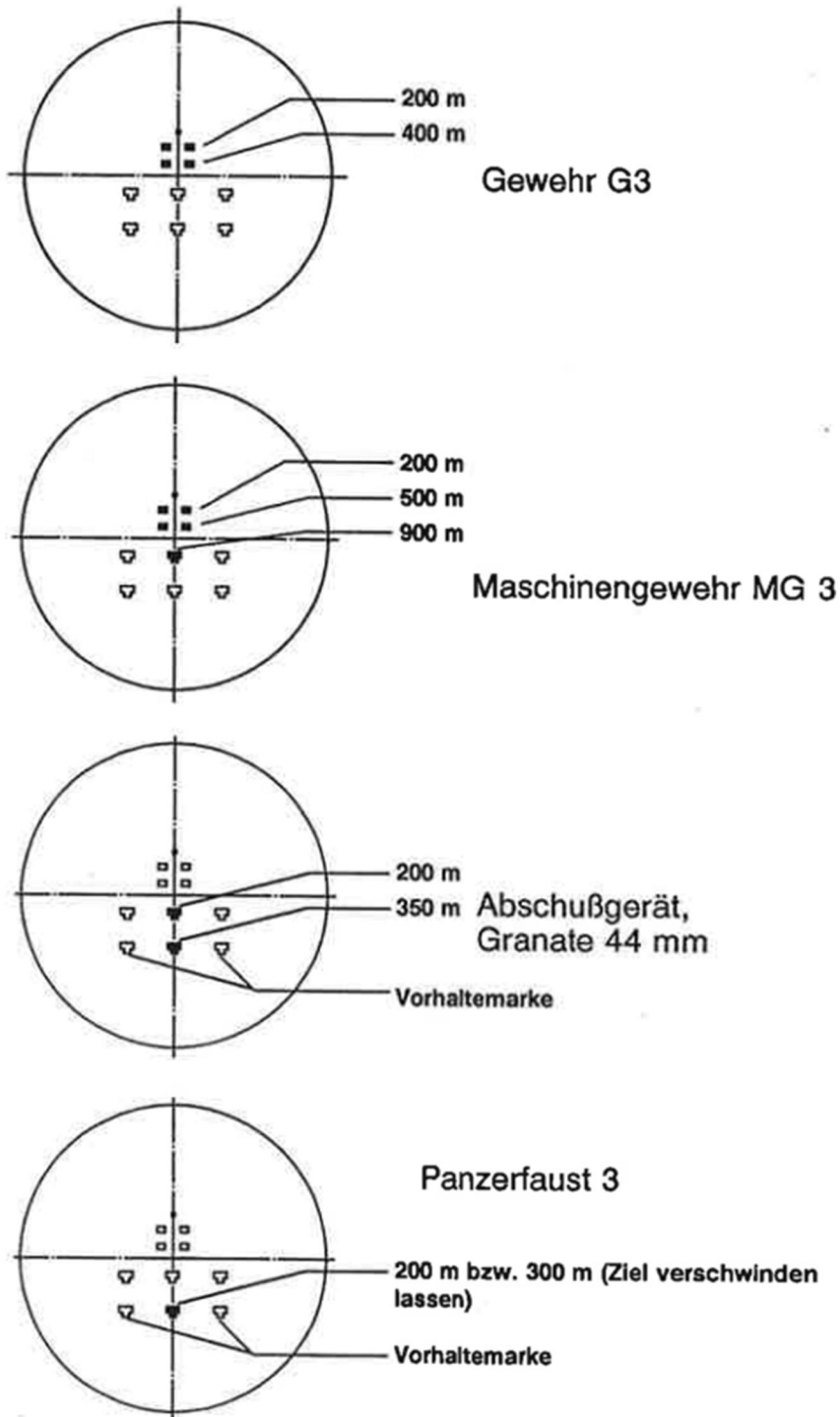

Figure 14 Orion 80 I Reticle

G3, MG 3, Grenate 44mm, Panzerfaust 3

1.3.5 ORION 80 II Reticle

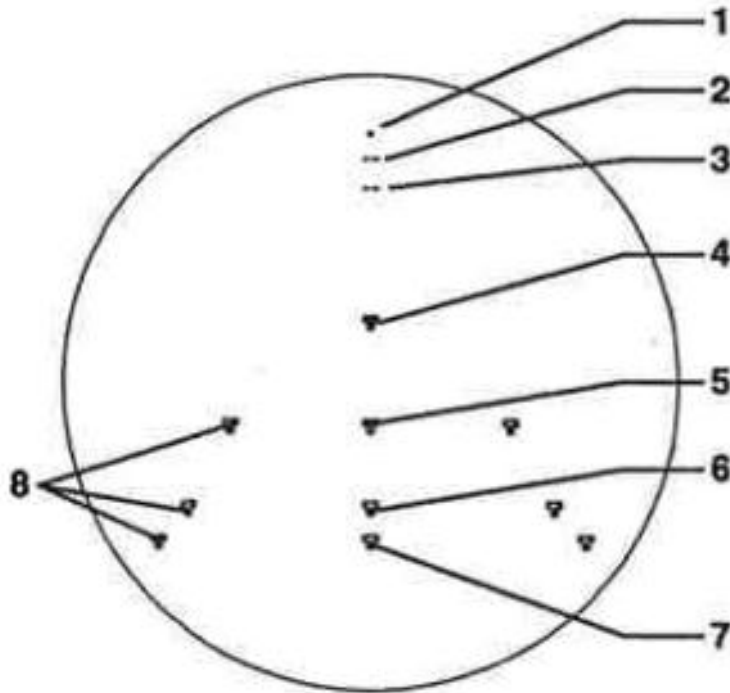
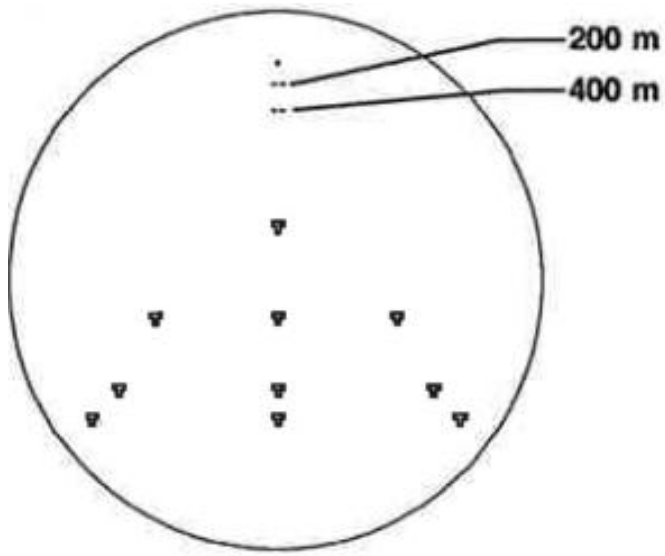
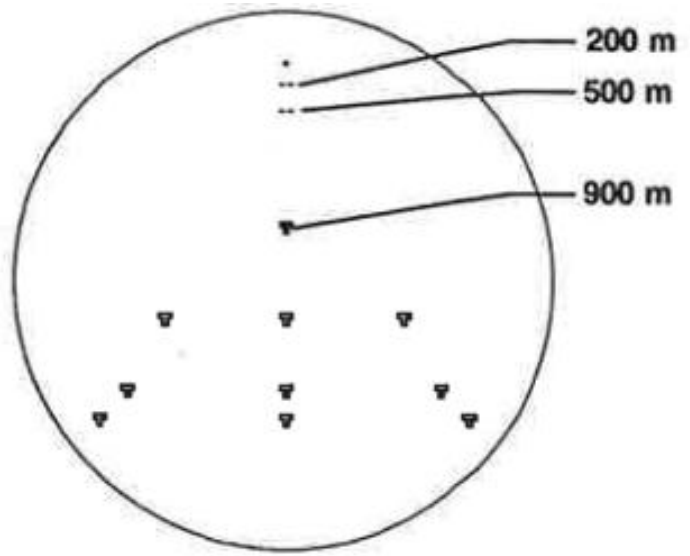

Figure 15 Reticle and Dimensions

- 1. Ballistic Zero**
- 2. 200m G3 and MG3**
- 3. 400m G3
500m MG3**
- 4. 900m MG3
100m Pzf 44 and Pzf 3**
- 5. 150m Pzf 44
200m Pzf 3**
- 6. 200m Pzf 44**
- 7. 300m Pzf 3**
- 8. Lead marks for Pzf 44 and Pzf 3, corresponds to vehicle speed of 25 km/h**



Gewehr G3



Maschinengewehr MG 3

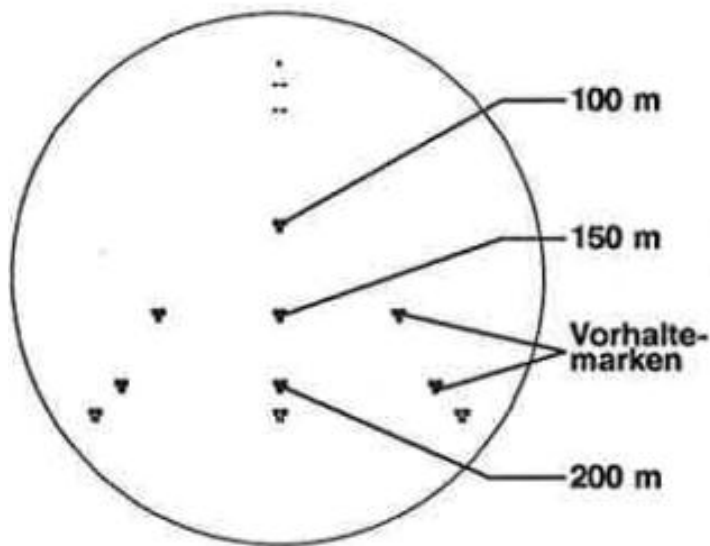

Abschußgerät,
Granate 44 mm

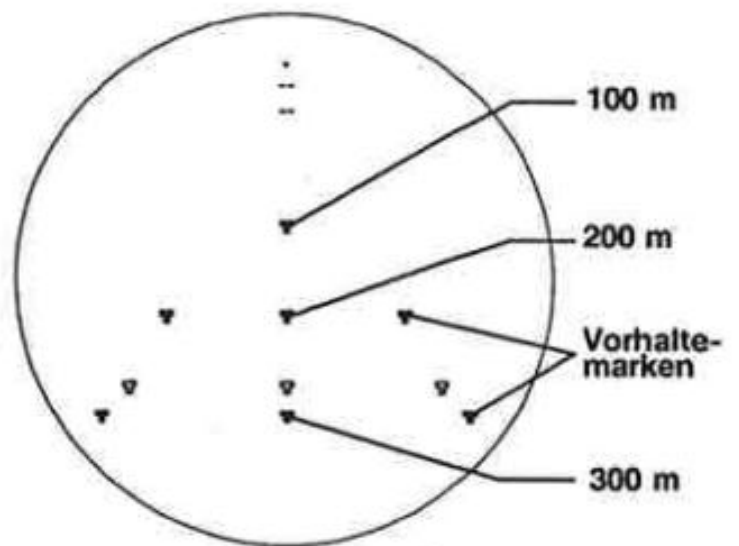

Panzerfaust 3

Figure 16 Orion 80 II Reticle
G3, MG 3, Grenate 44mm, Panzerfaust 3

1.3.5 Method of Operation

The residual light within view of the scope comes through the front lens (10/13) into the unit itself. The objective (10/14) creates an image which is imperceptible to the human eye on the cathode (10/9) of the light intensifier tube (10/8). At the same time, the reticle image (Fig 13 and 15) is projected by the mirrors (10/1), through the objective and onto the cathode. When the unit is turned on, the image intensifier tube amplifies the image of the target and reticle into a visible image. The image is displayed on the anode(10/6) of the light intensifier tube which is used as a fluoroscope, and can be seen by the viewer through the ocular (10/7).

The focus is adjustable for the user with the diopter adjustment ring.

The sensitive cathode is protected against daylight by an objective protection cap and a mechanical shutter. The shutter is arranged so that the optical path opens when the device is turned on and closes when it is turned off.

The reticle image is illuminated by a light emitting diode (10/3), whose sight marks are only visible when the night vision telescope is on. The brightness is adjustable and can be adjusted for windage (11/1) and elevation (11/4).

1.4 Equipment

NOTE: Required for the equipment is the Enclosure sheet AAN 5855-12-166-5705 for the ORION 80 I and Enclosure sheet AAN 5855-12-330-9130 for the ORION 80 II.

1.4.1 Storage Case ORION 80 I



Figure 17 Storage Case for the Night Vision Telescope

1. Storage Case
2. Upper foam Insert
3. Contents list
4. Lower foam insert

The night vision telescope, accessories and tools are stored in the case (17/1). It includes expanded foam inserts, the upper (17/2) and lower (17/4) pieces, as protection and for arranging the contents of the case.

1.4.2 Accessories and parts ORION 80 I

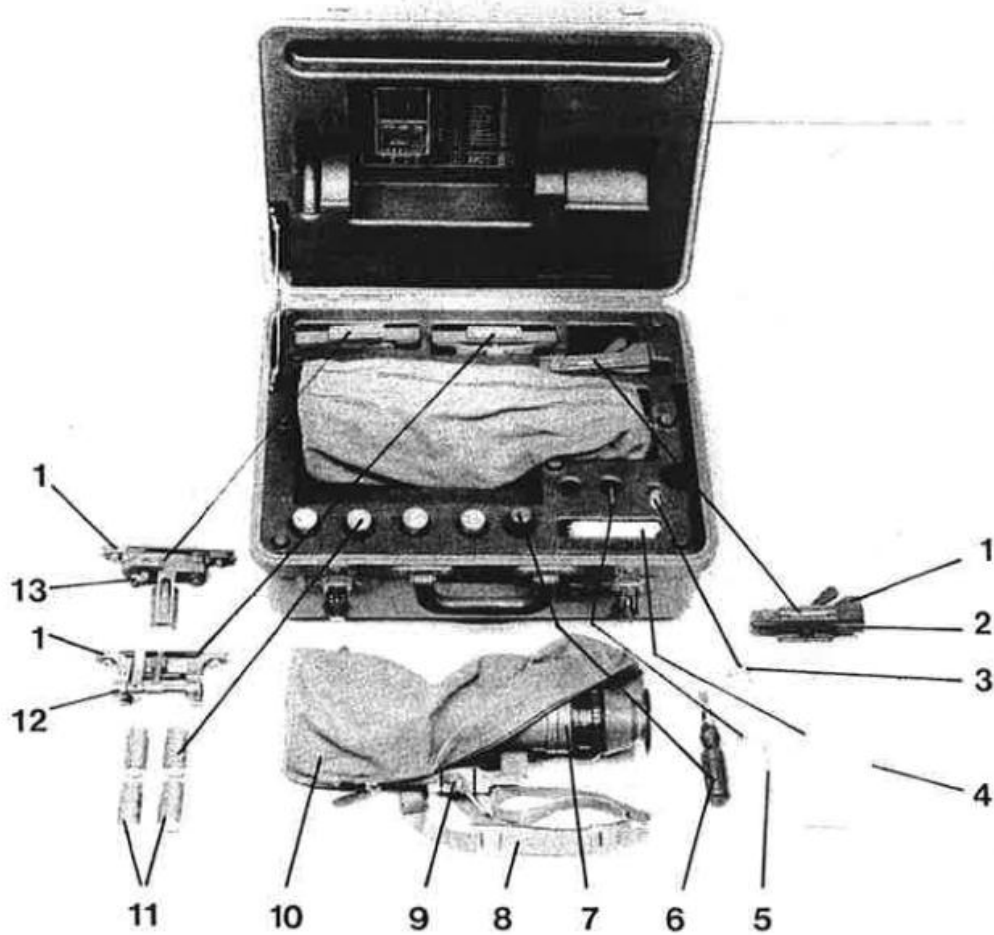

Figure 18 Accessories and Spare Parts

1. Mounts (3)
2. Pzf mount
3. TDv 5855/013-13
4. Spring attachment part
5. Lens cleaning cloth
6. Allen head Driver 4mm
7. Allen Head Driver 2.5x5mm
8. Screw Driver 10x2.5mm
9. Night Vision Sight
10. Clamp
11. Carry Strap
12. Canvas Pouch
13. Batteries
14. G3 Mount
15. MG Mount

1.4.3 Storage Case ORION 80 II

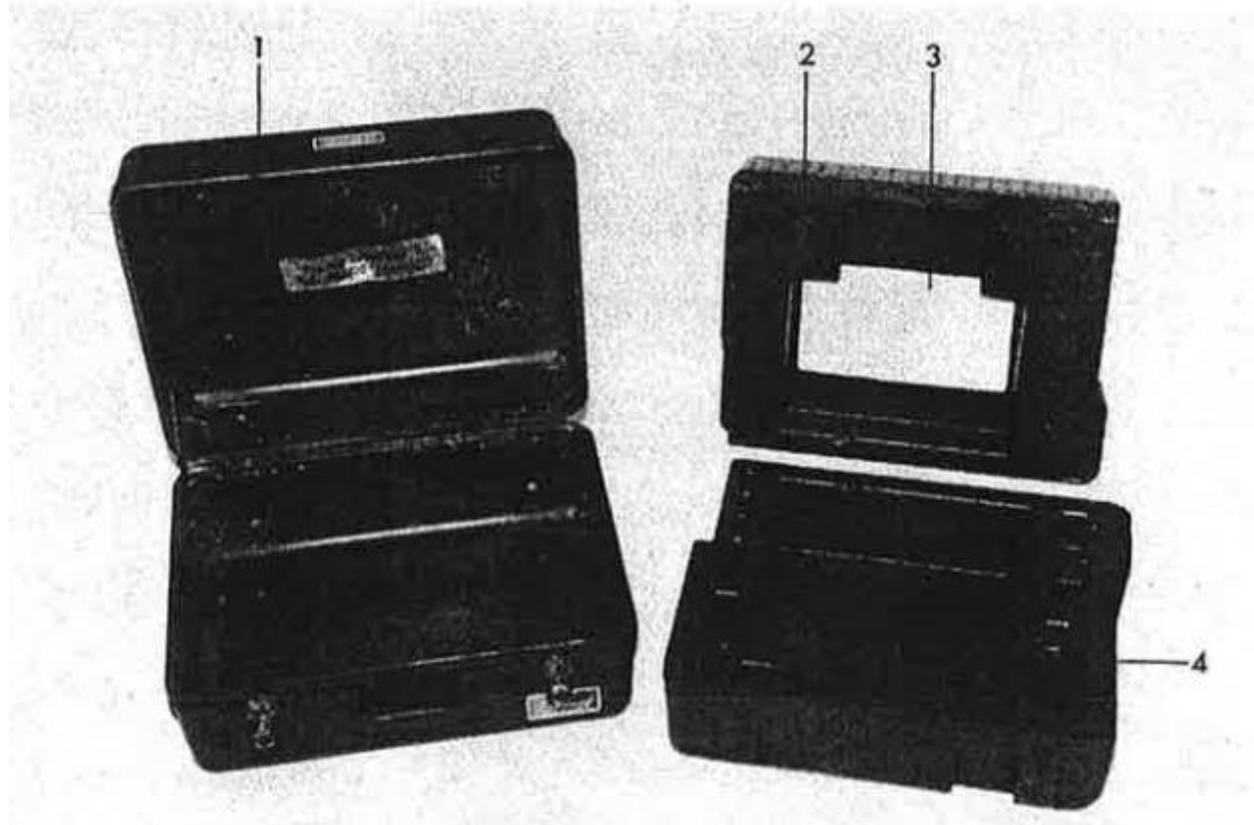

Figure 19 Storage Case for the Night Vision Telescope

1. Storage Case
2. Upper foam Insert
3. Contents list
4. Lower foam insert

The ORION 80 II, accessories and tools are stored in the case (19/1). It includes expanded foam inserts, the upper (19/2) and lower (19/4) pieces, as protection and for arranging the contents of the case.